

User Manual

WISE-4610(P)

**Industrial LoRaWAN Wireless I/O
Module**

ADVANTECH

Enabling an Intelligent Planet

Copyright

The documentation and the software included with this product are copyrighted 2024 by Advantech Co., Ltd. All rights are reserved. Advantech Co., Ltd. also reserves the right to improve the products described in this manual at any time without notice. No part of this manual may be reproduced, copied, translated, or transmitted in any form or by any means without the prior written permission of Advantech Co., Ltd. The information provided in this manual is intended to be accurate and reliable. However, Advantech Co., Ltd. assumes no responsibility for its use, nor for any infringements of the rights of third parties that may result from its use.

Acknowledgments

Intel and Pentium are trademarks of Intel Corporation.

Microsoft Windows and MS-DOS are registered trademarks of Microsoft Corp.

All other product names or trademarks are properties of their respective owners.

Product Warranty (2 years)

Advantech warrants the original purchaser that each of its products will be free from defects in materials and workmanship for two years from the date of purchase.

This warranty does not apply to any products that have been repaired or altered by persons other than repair personnel authorized by Advantech, or products that have been subject to misuse, abuse, accident, or improper installation. Advantech assumes no liability under the terms of this warranty as a consequence of such events.

Because of Advantech's high quality-control standards and rigorous testing, most customers never need to use our repair service. If an Advantech product is defective, it will be repaired or replaced free of charge during the warranty period. For out-of-warranty repairs, customers are billed according to the cost of replacement materials, service time, and freight. Please consult your dealer for more details.

If you believe your product is defective, follow the steps outlined below:

1. Collect all the information about the problem encountered. (For example, CPU speed, Advantech products used, other hardware and software used, etc.) Note anything abnormal and list any onscreen messages displayed when the problem occurs.
2. Call your dealer and describe the problem. Please have your manual, product, and any helpful information readily available.
3. If your product is diagnosed as defective, obtain a return merchandise authorization (RMA) number from your dealer. This allows us to process your return more quickly.
4. Carefully pack the defective product, a completed Repair and Replacement Order Card, and proof of the purchase date (such as a photocopy of your sales receipt) into a shippable container. Products returned without a proof of purchase date are not eligible for warranty service.
5. Write the RMA number clearly on the outside of the package and ship the package prepaid to your dealer.

Part No.
Printed in Taiwan

Edition 1
September 2024

Declaration of Conformity

CE

This product has passed the CE test for environmental specifications when shielded cables are used for external wiring. We recommend the use of shielded cables. This type of cable is available from Advantech. Please contact your local supplier for ordering information.

Test conditions for passing also include the equipment being operated within an industrial enclosure. In order to protect the product from damage caused by electrostatic discharge (ESD) and EMI leakage, we strongly recommend the use of CE-compliant industrial enclosure products.

FCC Class A

This equipment has been tested and found to comply with the limits for a Class A digital device, pursuant to part 15 of the FCC Rules. These limits are designed to provide reasonable protection against harmful interference when the equipment is operated in a commercial environment. This equipment generates, uses, and can radiate radio frequency energy and, if not installed and used in accordance with the instruction manual, may cause harmful interference to radio communications. Operation of this equipment in a residential area is likely to cause harmful interference. In this event, users are required to correct the interference at their own expense.

Technical Support and Assistance

1. Visit the Advantech website at www.advantech.com/support to obtain the latest product information.
2. Contact your distributor, sales representative, or Advantech's customer service center for technical support if you need additional assistance. Please have the following information ready before calling:
 - Product name and serial number
 - Description of your peripheral attachments
 - Description of your software (operating system, version, application software, etc.)
 - A complete description of the problem
 - The exact wording of any error messages

研華股份有限公司

網站: www.advantech.com.tw

地址: 台灣台北市內湖區瑞光路 26 巷 20 弄 1 號

電話: +886-2-27927818

Warnings, Cautions, and Notes

Warning! Warnings indicate conditions that if not observed may cause personal injury!



Caution! Cautions are included to help prevent hardware damage or data losses. For example, “Batteries are at risk of exploding if incorrectly installed. Do not attempt to recharge, force open, or heat the battery. Replace the battery only with the same or equivalent type as recommended by the manufacturer. Discard used batteries according to the manufacturer’s instructions.”



Note! Notes provide additional optional information.



Document Feedback

To assist us with improving this manual, we welcome all comments and constructive criticism. Please send all feedback in writing to support@advantech.com.

Packing List

Before system installation, check that the items listed below are included and in good condition. If any item is missing or damaged, contact your dealer immediately:

- 1 x WISE-4610 module
- 1 x Antenna
- 1 x Mount bracket
- 1 x WISE-4610 startup manual

Note! I/O boards for pairing with WISE-4610 are available for order:



- WISE-S614 4AI/4DI with M12 Connectors
- WISE-S614T 4AI/4DI with Terminal Block
- WISE-S615T 4RTD with Terminal Block
- WISE-S615 4RTD with M12 Connectors
- WISE-S617 2AI/2DI/1DO/1RS-485 with M12 Connectors
- WISE-S617T 2AI/2DI/1DO/1RS-485 with Terminal Block
- WISE-S672 6DI/1RS-485/1RS-485 or RS-232 with M12 Connectors

Note! A micro-B USB cable for configuring WISE-4610 nodes is available for order:



- **1700023619-01** Micro USB type-B male to USB type-A male cable, 1 M

Note! An M12 connector and cable for I/O or power wiring is available for order:



- **1654011516-01** M12, A-code, 8 Pin, Male
- **1655005903-01** M12, A-code, 4 Pin, Female
- **1700028162-01** M12, A-code, 4 pin, Female with 1M cable
- **1700028163-01** M12, A-code, 8 Pin, Male with 1M cable

Safety Instructions

1. Read these safety instructions carefully.
2. Retain this user manual for future reference.
3. Disconnect the equipment from all AC outlets before cleaning. Use only a damp cloth for cleaning. Do not use liquid or spray detergents.
4. For pluggable equipment, the power outlet socket must be located near the equipment and easily accessible.
5. Place the equipment on a reliable surface during installation. Dropping or letting the equipment fall may cause damage.
6. The openings on the enclosure are for air convection. Protect the equipment from overheating. Do not cover the openings.
7. Ensure that the voltage of the power source is correct before connecting the equipment to a power outlet.
8. Position the power cord away from high-traffic areas. Do not place anything over the power cord.
9. All cautions and warnings on the equipment should be noted.
10. If the equipment is not used for a long time, disconnect it from the power source to avoid damage from transient overvoltage.
11. Never pour liquid into an opening. This may cause fire or electrical shock.
12. Never open the equipment. For safety reasons, the equipment should be opened only by qualified service personnel.
13. If one of the following occurs, have the equipment checked by qualified service personnel:
 - The power cord or plug is damaged.
 - Liquid has penetrated the equipment.
 - The equipment has been exposed to moisture.
 - The equipment is malfunctioning, or does not operate according to the user manual.
 - The equipment has been dropped and damaged.
 - The equipment shows obvious signs of breakage.
14. Do not leave the equipment in an environment with a storage temperature of below -20 °C (-4 °F) or above 60 °C (140 °F) as this may cause damage. The equipment should be kept in a controlled environment.
15. CAUTION: Batteries are at risk of exploding if incorrectly replaced. Replace only with the same or equivalent type as recommended by the manufacturer. Discard used batteries according to the manufacturer's instructions.
16. According to IEC 704-1:1982 standards, the sound pressure level at the operator's position does not exceed 70 dB (A).

DISCLAIMER: These instructions are provided in accordance with IEC 704-1. Advantech disclaims all responsibility for the accuracy of any statements contained herein.

Safety Precautions - Static Electricity

Follow these simple precautions to protect yourself from harm and the products from damage:

- Disconnect the power supply before making any configuration changes. The sudden rush of power after connecting a jumper or installing a card may damage sensitive electronic components.

NCC 警语

根據低功率電波輻射性電機管理辦法

第十二條 經型式認證合格之低功率射頻電機，非經許可，公司、商號或使用者均不得擅自變更頻率、加大功率或變更原設計之特性及功能。

第十四條 低功率射頻電機之使用不得影響飛航安全及干擾合法通信；經發現有干擾現象時，應立即停用，並改善至無干擾時方得繼續使用。前項合法通信，指依電信法規定作業之無線電通信。低功率射頻電機須忍受合法通信或工業、科學及醫療用電波輻射性電機設備之干擾。

Federal Communication Commission Interference Statement

This device complies with Part 15 of the FCC Rules. Operation is subject to the following two conditions: (1) the device may not cause harmful interference, and (2) the device must accept any interference received, including interference that may cause undesired operation.

COUNTRY CODE SELECTION (WLAN DEVICES)

The country code selection option is available for the non-U.S. model only, and is not available for any U.S. models. According to the FCC regulations, all Wi-Fi products marketed in the U.S. must be fixed to U.S. operation channels only.

Industry Canada statement:

This device complies with ISED's licence-exempt RSSs. Operation is subject to the following two conditions: (1) the device may not cause harmful interference, and (2) the device must accept any interference received, including interference that may cause undesired operation.

Le présent appareil est conforme aux CNR d'ISED applicables aux appareils radio exempts de licence. L'exploitation est autorisée aux deux conditions suivantes: (1) le dispositif ne doit pas produire de brouillage préjudiciable, et (2) ce dispositif doit accepter tout brouillage reçu, y compris un brouillage susceptible de provoquer un fonctionnement indésirable.

Contents

Chapter 1	Product Introduction	1
1.1	LoRa and LoRaWAN.....	2
1.2	WISE-4610 Feature Highlights.....	2
1.3	WISE Series Family	2
	Table 1.1: WISE Series Family.....	2
1.4	System Diagram.....	3
	Figure 1.1 WISE-4610 System Diagram.....	3
1.5	Battery Switch	3
	Figure 1.2 WISE-4610 Battery Switch	3
1.6	LED Indicators.....	4
	Figure 1.3 WISE-4610 LED Indicators.....	4
	Table 1.2: LED Indicators	4
	Table 1.3:	5
1.7	Membrane Button.....	5
	Figure 1.4 WISE-4610 Membrane Button.....	5
1.8	Packing List.....	6
Chapter 2	Hardware Installation	7
2.1	Modular Design	8
	Figure 2.1 I/O Module Installation	8
2.2	System Dimensions	9
	Figure 2.2 WISE-4610 Dimensions	9
	Figure 2.3 WISE-S600 Series I/O Module Dimensions	10
2.3	DIN-Rail Mounting	10
	Figure 2.4 WISE-4000 Series Mount Kit Dimensions	10
	Figure 2.5 DIN-Rail Mounting Adapter Installation	11
	Figure 2.6 DIN-Rail Mounting (Front View).....	11
	Figure 2.7 DIN-Rail Mounting (Rear View)	12
2.4	Wall Mounting	12
	Figure 2.8 Wall Mount Bracket Installation	12
2.5	Pole Mounting	13
	Figure 2.9 Pole Mount Bracket Installation (Front View)	13
	Figure 2.10 Pole Mount Bracket Installation (Rear View)	13
Chapter 3	Hardware Specifications	15
3.1	LoRa (Model: WISE-4610P).....	16
3.2	GPS.....	16
3.3	General	16
3.4	Power	17
3.5	I/O Specifications	17
	3.5.1 WISE-S614/WISE-S614T I/O Module.....	17
	3.5.2 WISE-S615/WISE-S615T RTD I/O Module	18
	3.5.3 WISE-S617/WISE-S617T I/O Module.....	18
	3.5.4 WISE-S672 I/O Module.....	19
3.6	I/O Pin Assignment	21
	Figure 3.1 WISE-S600 Pin Out.....	21
	Table 3.1: I/O Pin Assignment.....	21
3.7	Pin Assignment of WISE-S600T I/O Module with Terminal Block Connectors.....	22
3.8	Application Wiring of WISE-S600 I/O Module with M12 Connectors	23
	3.8.1 WISE-S614 I/O Application Wiring.....	23

	Figure 3.2 WISE-S614 I/O Application Wiring	23
3.8.2	WISE-S615 I/O Application Wiring	23
	Figure 3.3 WISE-S615 I/O Application Wiring	23
3.8.3	WISE-S617 I/O Application Wiring	24
	Figure 3.4 WISE-S617 I/O Application Wiring Diagram	24
3.8.4	WISE-S672 Application Wiring	24
	Figure 3.5 WISE-S672 Application Wiring Diagram	24
3.9	Application Wiring of WISE-S600T I/O Module with Terminal Block	25
3.9.1	WISE-S614T I/O Application Wiring	25
	Figure 3.6 WISE-S614T I/O Application Wiring Diagram	25
3.9.2	WISE-S617T I/O Application Wiring	25
	Figure 3.7 WISE-S617T I/O Application Wiring Diagram	25
3.10	Power Supply Wiring.....	26
3.11	Block Diagram.....	26
	Figure 3.8 WISE-4610 Block Diagram.....	26
3.12	Configuration Interface.....	26

Chapter 4 Software Functions..... 27

4.1	System Structure	28
4.2	Interface Design.....	30
4.2.1	LoRaWAN Functions	30
	Table 4.1: LoRaWAN Functions.....	30
	Table 4.2: Configuration Parameters for LoRaWAN	30
4.2.2	Positioning	31
	Table 4.3: Features	31
	Table 4.4: Measurement Data.....	31
	Table 4.5: Configurations	32
4.2.3	LED Indicator Behaviors.....	32
	Table 4.6: LED Indicator Behaviors.....	32
	Table 4.7:	33
4.2.4	Battery Charging.....	33
	Table 4.8:	33
	Table 4.9:	34
	Table 4.10: Battery Events.....	34
	Table 4.11: Battery Temperature and Charging.....	35
4.2.5	Membrane Button	35
4.2.6	Multiple Power Sources	36
	Table 4.12:	36
	Table 4.13:	36
4.3	Connection Setting on WISE-4610	37
4.3.1	Configure WISE-4610 by Using WISE-Studio	37

Appendix A Modbus Table with WISE-4610 47

Table A.1: WISE-4610-S617 (for WISE-6610 LoRaWAN GW) .	48
Table A.2: *AI Status: (1st Register at Low Address).....	50
Table A.3: *4 Power source	50
Table A.4: Modbus Type Code	50
Table A.5: WISE-4610-S615 (for WISE-6610 LoRaWAN GW) .	51
Table A.6: *AI Status: (1st Register at Low Address).....	52
Table A.7: *4 Power source	53
Table A.8: Modbus Type Code	53

Chapter 1

Product Introduction

1.1 LoRa and LoRaWAN

A low-power, wide-area network (LPWAN) is a type of wireless telecommunication wide-area network designed to allow long-range communications at a low bit rate between IoT devices, such as battery-operated sensors.

LPWAN offers multi-year battery lifetime and is designed for sensors and applications that need to send small amounts of data over long distances a few times per hour from varying environments.

LoRa and LoRaWAN belong to the category of non-cellular LPWAN wireless communication network protocols that enable long-range data transmissions with low power consumption, and operate in the license-free spectrum.

LoRa is a patented digital wireless data communication IoT technology. The technology is presented in two parts — LoRa, the physical layer (PHY), and the communication protocol built upon the underlying LoRa physical layer. The communication layer may be LoRaWAN, an open-source communication protocol defined by the LoRa Alliance consortium.

The difference between LoRa and LoRaWAN is that LoRaWAN defines the communication protocol and system architecture for the network, while the LoRa physical layer enables the long-range communication link.

1.2 WISE-4610 Feature Highlights

Advantech's WISE-4610 LoRa wireless I/O module can be configured to support either a public or private LoRa using the WISE Studio utility via a USB port.

For outdoor applications, WISE-4610 can be equipped with optional GPS, a solar rechargeable battery, and an IP65-rated enclosure to protect from water and dust ingress.

The WISE-4610 wireless I/O module features an intelligent modular design that supports various I/O configurations according to usage requirements. This allows users to easily integrate their desired I/O module (WISE-S614/S615/S617/S672) with the WISE-4610 module.

1.3 WISE Series Family

Table 1.1: WISE Series Family

Function	Model	Description
LoRa Wireless I/O Module	WISE-4610	Outdoor LoRa wireless I/O module
I/O Module	WISE-S672	I/O module with 6 x digital inputs, 1 x RS-485 port, and 1 x RS-232/485 port
	WISE-S617	I/O module with 2 x analog input, 2 x digital input, 1 x digital output, 1 x RS-485 port
	WISE-S615	I/O module with 4 x RTD channels
	WISE-S614	I/O module with 4 x digital inputs and 4 x analog inputs
LoRa Gateway	WISE-6610	LoRaWAN Gateway

1.4 System Diagram

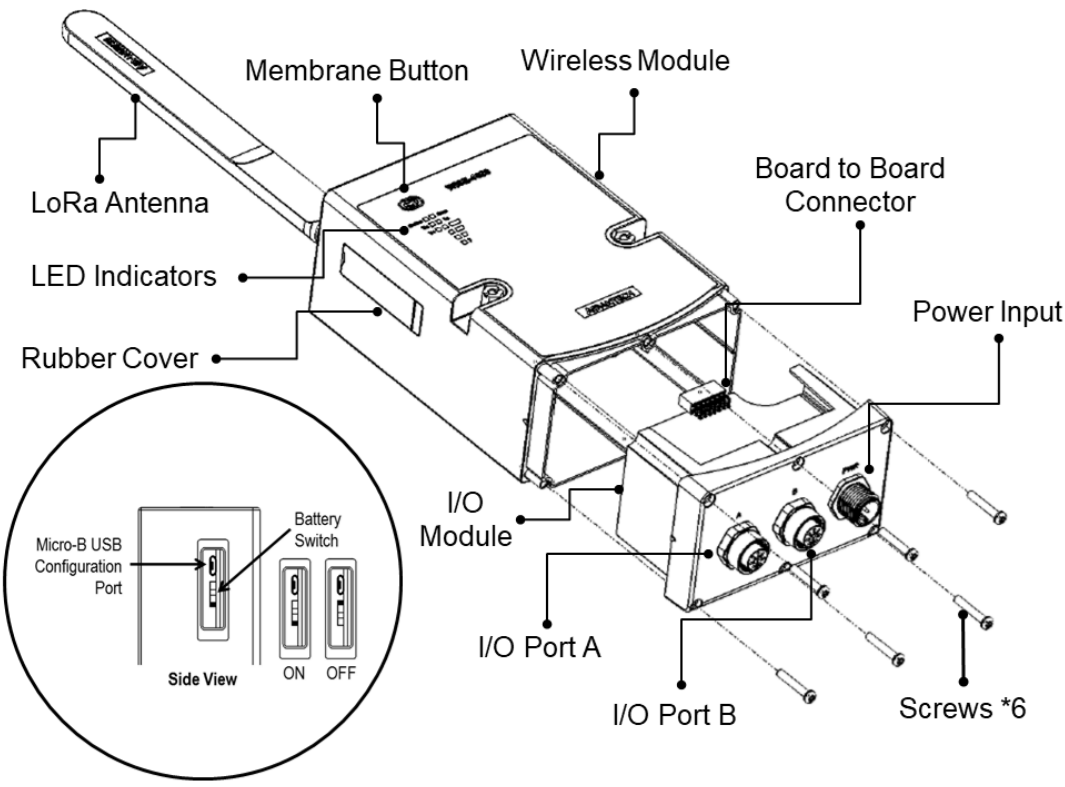

Figure 1.1 WISE-4610 System Diagram

1.5 Battery Switch

The WISE-4610 module is equipped with a switch to turn the battery ON/OFF. This switch is located at the side of the WISE-4610 module. Simply open the rubber cover and flick the switch to turn ON/OFF the battery power.

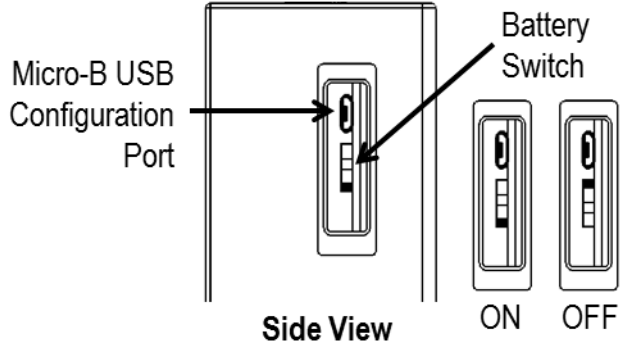

Figure 1.2 WISE-4610 Battery Switch

1.6 LED Indicators

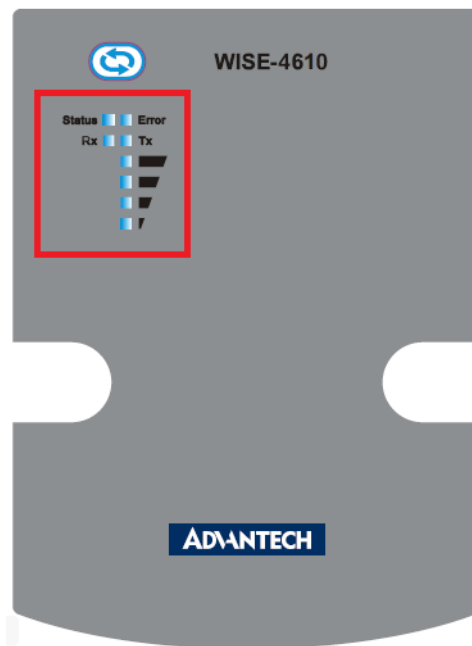

Figure 1.3 WISE-4610 LED Indicators

Table 1.2: LED Indicators

LED	Color	State	Description
Status	Green	Fast blink (0.2 sec ON, 0.3 sec OFF)	Waiting for connection or connecting
		Slow blink (0.2 sec ON, 1.8 sec OFF)	Connecting and operating normally
Error	Red	Fast blink (0.2 sec ON, 0.8 sec OFF)	Application errors. (*Note 1) <ul style="list-style-type: none"> ■ Network registration timeout ■ I/O Error ■ FW error
		Slow blink (0.2 sec ON, 2.8 sec OFF)	<ul style="list-style-type: none"> ■ Low battery voltage ($v \leq 20\%$) ■ Low RTC battery voltage ■ Battery internal short is detected
		Off	No error
		RF RX	Green
RF TX	Yellow	On	Sending data to gateway
		Off	Idle
Signal Strength	4 Green	On (if pressing the membrane button)	Main battery capacity <ul style="list-style-type: none"> ■ All OFF - $V \leq 20\%$ ■ 1 ON - $20\% < V < 40\%$ ■ 2 ON - $40\% \leq V < 60\%$ ■ 3 ON - $60\% \leq V < 80\%$ ■ 4 ON - $V \geq 80\%$
		Off	

*Note 1

Table 1.3:

Error LED	Signal LEDs				Description
	1st (poor)	2nd (Okay)	3rd (Good)	4th (Full)	
	OFF	OFF	OFF	Fast Blink	RF related Error
Fast Blink	OFF	OFF	Fast Blink	OFF	I/O Error
Error	OFF	OFF	OFF	OFF	FW error
Slow Blink	OFF	OFF	OFF	OFF	Battery related Error
OFF	OFF	OFF	OFF	OFF	No error

Note! If WISE-4610 is powered by the battery, the LED indicators will turn off after 15 seconds to save power.



1.7 Membrane Button

Located at the front of the WISE-4610 module is a membrane button that can be used to switch between operating modes and to light up the LED indicators (refer to Section 4.2.9 “LoRaWAN Functions” for more information about the membrane button functions).

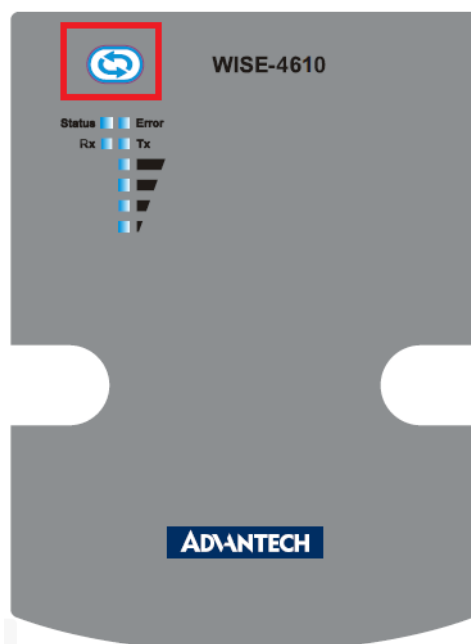

Figure 1.4 WISE-4610 Membrane Button

1.8 Packing List

WISE-4610 LoRa Wireless I/O Module

- 1 x WISE-4610 module
- 1 x Antenna
- 1 x Mount bracket
- 1 x WISE-4610 startup manual

WISE-S614/WISE-S614T 4AI/4DI I/O Module

- 1 x WISE-S614 module
- 1 x I/O information label

WISE-S615/WISE-S615T 4RTD I/O Module

- 1 x WISE-S615 or WISE-S615T I/O Module
- 1 x I/O Information Label

WISE-S617/WISE-S617T 2AI, 2DI, 1DO & 1RS-485 I/O Module

- 1 x WISE-S617 or WISE-S617T I/O Module
- 1 x I/O Information Label

WISE-S672 6DI/1RS-485/1RS-485 or RS-232 Module

- 1 x WISE-S672 module
- 1 x I/O information label

Note! Refer to the WISE-6610 user manual for information on how to configure a LoRaWAN gateway.



Note! A micro-B USB cable for configuring WISE-4610 is available for order:



- **1700023619-01** Micro USB type-B male to USB type-A male cable, 1 M

Note! An M12 connector and cable for I/O or power wiring is available for order:



- **1654011516-01** M12 connector, 8 pin, male
- **1655005903-01** M12 connector, 4 pin, male
- **1700028162-01** M12 code-A, 4 pin, female cable for power wiring, 2 M
- **1700028163-01** M12 code-D, 8 pin, male cable for I/O wiring, 2 M

Chapter 2

Hardware Installation

The wireless sensor nodes for WISE-4610, like those for all WISE-4000 series modules, are designed as separate units. The procedure for installing these nodes in the module is explained in the following sections.

2.1 Modular Design

WISE-4610 features a modular design that supports various I/O configurations.

The benefit of a modular design is that the same wireless board can be leveraged by different I/O modules via a board-to-board connector. This allows users to install two I/O modules according to their specific usage requirements. Moreover, the modules can be affixed to WISE-4610 using the six screws provided (as shown in Figure 2.1).

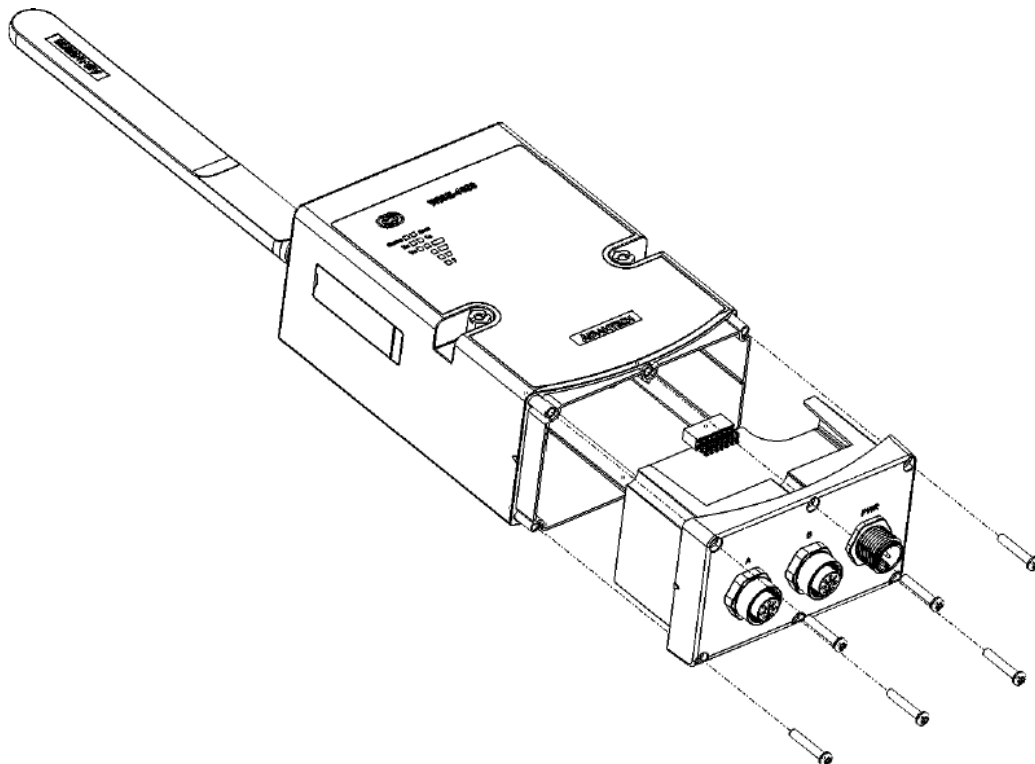

Figure 2.1 I/O Module Installation

Note! The recommended screw torque is $2.5 \sim 3.0 \text{ kgf/cm}^2$.



2.2 System Dimensions

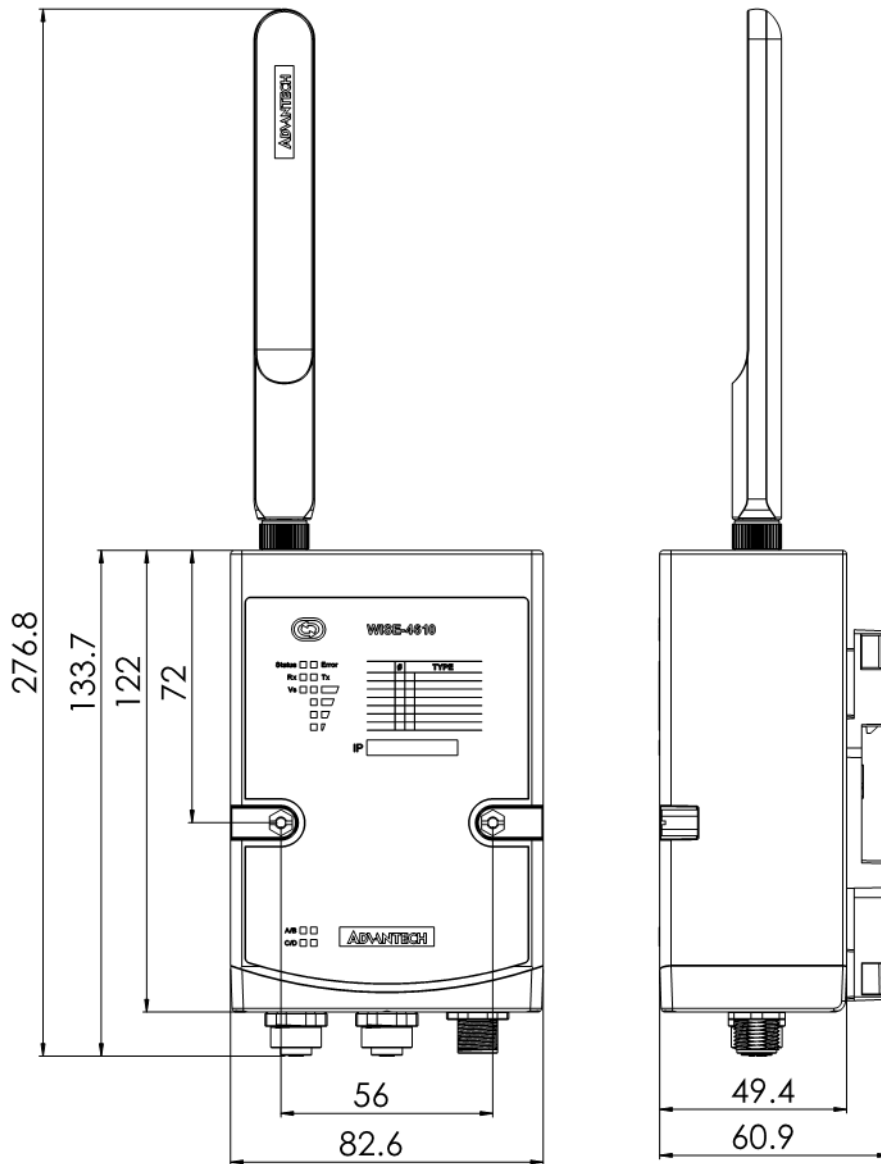

Figure 2.2 WISE-4610 Dimensions

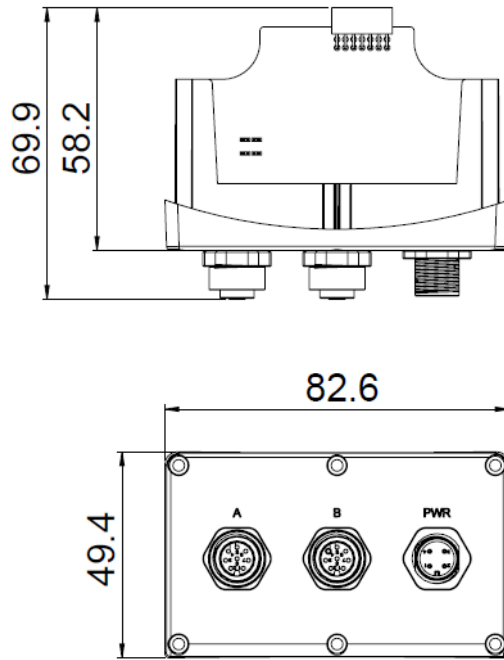

Figure 2.3 WISE-S600 Series I/O Module Dimensions

2.3 DIN-Rail Mounting

WISE-4610 modules can be fixed to a cabinet with mount rails. Use a flathead screwdriver to affix the DIN rail mounting adapter to the module. Then attach the end brackets provided with the product to prevent sliding.

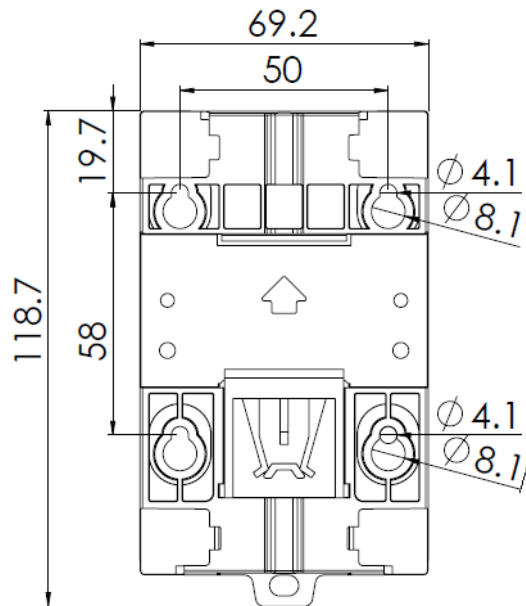

Figure 2.4 WISE-4000 Series Mount Kit Dimensions

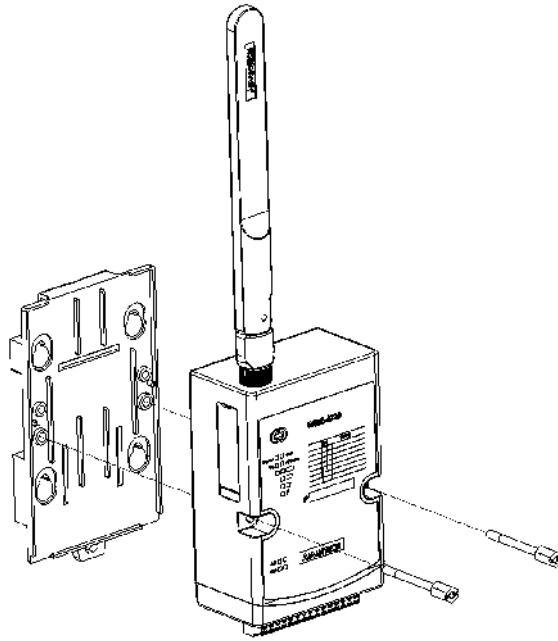

Figure 2.5 DIN-Rail Mounting Adapter Installation

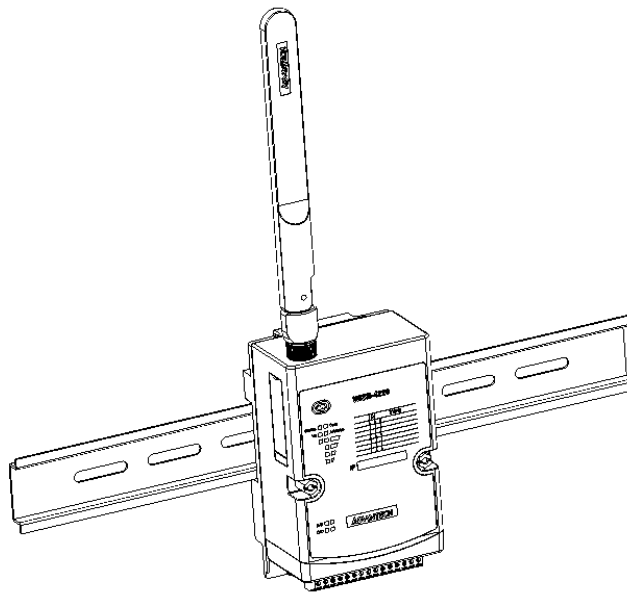

Figure 2.6 DIN-Rail Mounting (Front View)

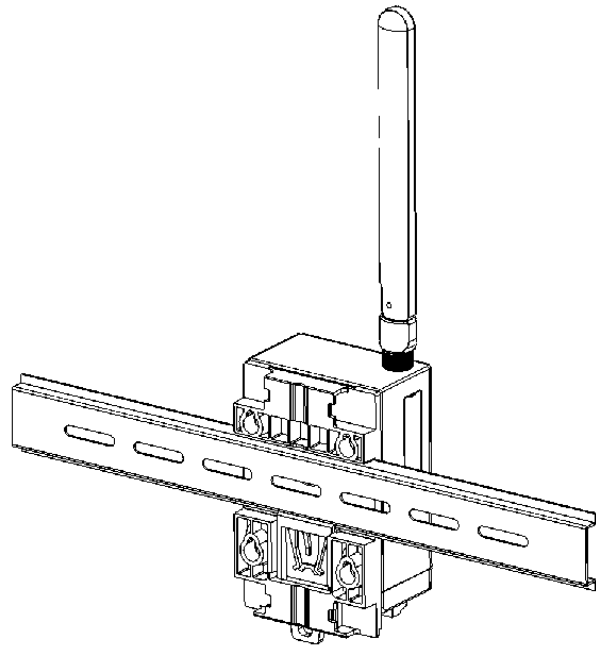

Figure 2.7 DIN-Rail Mounting (Rear View)

2.4 Wall Mounting

The plastic wall-mount bracket provided with the product, can be used to mount WISE-4610 on a wall, panel, or cabinet.

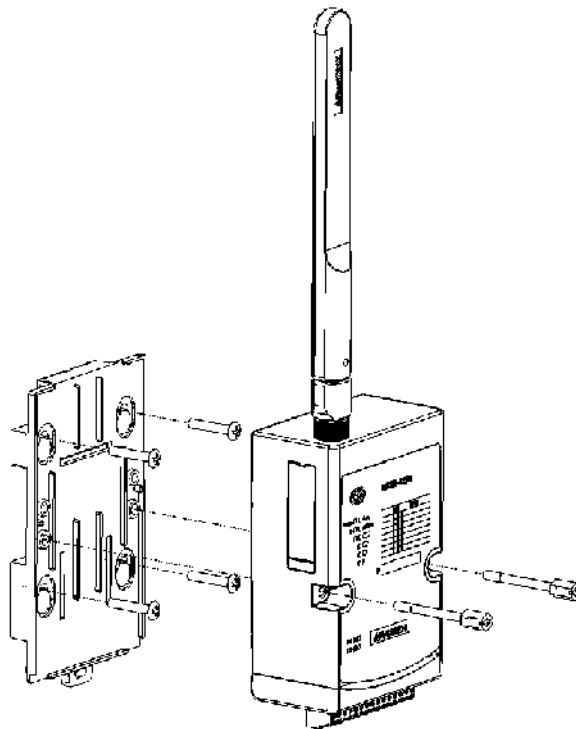

Figure 2.8 Wall Mount Bracket Installation

2.5 Pole Mounting

For pole mounting, feed the pole-mounting ring through the hole in the middle of the module. The pole-mounting ring must be unlocked with a screwdriver before inserting it into the module. To mount the module on the pole, tightly lock the pole-mounting ring.

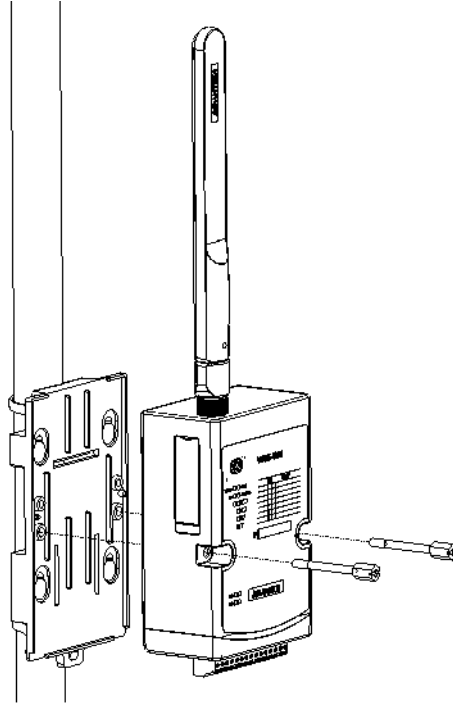

Figure 2.9 Pole Mount Bracket Installation (Front View)

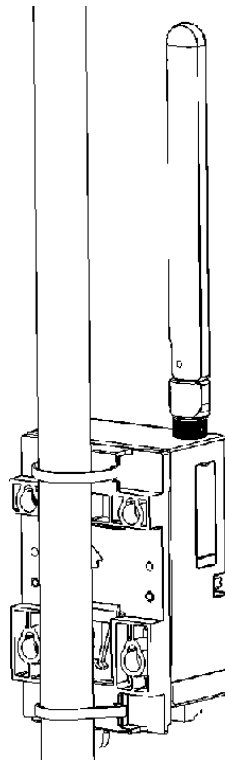

Figure 2.10 Pole Mount Bracket Installation (Rear View)

Chapter 3

Hardware
Specifications

3.1 LoRa (Model: WISE-4610P)

- **Frequency Band:** EU 863-870 (MHz)/US 902-928 (MHz)/AU 915-928 (MHz)/AS 919-924 (MHz)/JP 920-928 (MHz)
- **Spreading Factor:** 7~12
- **Transmit Power:** Up to +18 dBm
- **Receiver Sensitivity:** Up to -136 dBm at SF = 12/125 KHz
- **Data Rate:**
 - 50 kbps at FSK mode EU868
 - 21.9 kbps at SF7 mode US915
 - 5.47 kbps at SF7 mode JP923/AS923
- **Topology:** Star

3.2 GPS

- **GNSS Systems:** GPS, GLONASS, Galileo, BeiDou, QZSS, and SBAS signals
- **Maximum Update Rate:**
 - Single GNSS: Up to 18 Hz
 - Concurrent GNSS: Up to 10 Hz
- **Positioning Accuracy:**
 - 2.5 m CEP (50% confidence)
 - With SBAS: 2.0 m CEP (50% confidence)
- **Acquisition:**
 - Cold Starts: 57 s
 - Aided Starts: 7 s

3.3 General

- **RTC Accuracy:** ± 2 s/day
- **Enclosure:** PC + PBT
- **Mount Options:** DIN rail, wall, and pole
- **Dimensions (W x H x D):** 82 x 122 x 49 mm/3.22 x 4.8 x 1.92 in (without antenna)
- **Operating Temperature:**
 - With rechargeable battery: 0 ~ 60 °C (32 ~ 140 °F)
 - Without battery: -25 ~ 70 °C (-13 ~ 158 °F)
- **Storage Temperature:**
 - With rechargeable battery: -20 ~ 60 °C (-4 ~ 140 °F)
 - Without battery: -40 ~ 85 °C (-40 ~ 185 °F)
- **Operating Humidity:** 25 ~ 95% RH (non-condensing)
- **Storage Humidity:** 0 ~ 95% RH (non-condensing)

Note! *The storage and operation of WISE-4610 modules **MUST** be in environments that meet the temperature specifications.*



Note!  WISE-4610 modules can withstand operation in environments with less than 30% humidity. However, environments with low relative humidity are prone to causing electrostatic discharge issues. Therefore, users should take adequate precautions and use grounding straps, anti-static floor coverings, or similar equipment when manually handling the modules, especially in low-humidity environments.

Note!  Batteries are at risk of exploding if it is incorrectly installed. Do not attempt to replace the battery yourself. Batteries should only be replaced by qualified service personnel.

3.4 Power

- **Power Input Voltage:** 10 ~ 50 V_{DC}
- **Power Consumption:**
 - WISE-4610: 11 W @ 24 V, when the battery is charging
- **Solar Panel Input Voltage:** 17 ~ 50 V_{DC}
- **Battery Capacity:** 4000 mAh
- **Battery Life:** 6 months (with hourly data updates and daily GPS updates)

Note!  The battery life is estimated for temperatures of 25 °C. Operation in low-temperature environments will reduce the battery life.

3.5 I/O Specifications

- **Power Connector:** 1 x M12 4-pin code-A male connector with male pins
- **I/O Connector:** 2 x M12 8-pin code-D female connector with female pins

3.5.1 WISE-S614/WISE-S614T I/O Module

3.5.1.1 Digital Inputs

- **Channels:** 4
- **Logic Level (Dry Contact):**
 - 0: Open
 - 1: Close DI COM
- Non-isolation
- Supports 200 Hz counter input (32-bit + 1-bit overflow)
- Keep/discard counter value when power OFF
- Supports 200 Hz Frequency Input
- Supports inverted DI status

3.5.1.2 Analog Inputs

- **Channels:** 4
- **Resolution:** 16 bit
- **Sampling Rate:** 1 Hz per channel
- **Accuracy:**
 - $\pm 0.1\%$ of FSR (voltage)
 - $\pm 0.2\%$ of FSR (current)
- **Input Range:** ± 150 mV, ± 500 mV, ± 1 V, ± 5 V, ± 10 V, 0 ~ 150 mV, 0 ~ 500 mV, 0 ~ 1 V, 0 ~ 5 V, 0 ~ 10 V, 0 ~ 20 mA, 4 ~ 20 mA, ± 20 mA
- **Input Impedance:**
 - > 2 M Ω (Voltage)
 - 240 Ω (external resistor for current)
- **Isolation Voltage:** 3000 Vdc
- **Common Mode Voltage:** 350 V_{DC}
- **Burn-Out Detection:** Yes (4 ~ 20 mA only)
- Supports data scaling and averaging

3.5.2 WISE-S615/WISE-S615T RTD I/O Module

3.5.2.1 Analog Input

- **Channels:** 4 differential
- **Input Connections:** 2, 3-wire
- **Input Impedance:** 10 M Ω
- **Resolution:** 15 bits
- **Sampling Rate:** 1 Sample/s (MAX)
- **RTD Types and Temperature Ranges:**
 - Pt 100 RTD:
 - RTD 100 (a = 0.00385) -200 °C to 600 °C
 - RTD 100 (a = 0.00392) -200 °C to 600 °C
 - Pt 1000 RTD:
 - Pt -40 °C to 160 °C
- **Accuracy:** $\pm 0.1\%$ of FSR
- **CMR @ 50/60 Hz:** 90 dB
- **NMR @ 50/60 Hz:** 60 dB
- **Span Drift:** ± 100 ppm/°C

3.5.3 WISE-S617/WISE-S617T I/O Module

3.5.3.1 Digital Input

- **Channel:** 2
- **Logic Level (Dry Contact):**
 - 0: Open
 - 1: Close to DI COM
- Non-isolation
- Supports 32-bit counter input function (maximum signal frequency: 200 Hz)
- Supports keep/discard counter value when power OFF
- Supports frequency input function (maximum signal frequency: 200 Hz)
- Supports inverted digital input status

3.5.3.2 Analog Input

- **Channels:** 2
- **Resolution:** 16 bit
- **Sampling Rate:** 1 Hz per channel
- **Accuracy:**
 - $\pm 0.1\%$ of FSR (Voltage)
 - $\pm 0.2\%$ of FSR (Current)
- **Input Range:** ± 1 V, ± 5 V, ± 10 V, 0 ~ 1 V, 0 ~ 5 V, 0 ~ 10 V, 0 ~ 20 mA, 4 ~ 20 mA, ± 20 mA
- **Input Impedance:**
 - > 2 M Ω (Voltage)
 - 120 Ω (External Resistor for Current)
- **Isolation Voltage:** 2000 VRMS
- **Common Mode Voltage:** 350 V_{DC}
- **Drift:**
 - Unipolar: ± 100 ppm
 - Bipolar: ± 50 ppm
- **Burn-Out Detection:** Yes (4 ~ 20 mA only)
- Supports data scaling and averaging

3.5.3.3 Digital Output

- **Channel:** 1 (Sink Type)
- Non-isolation
- **Output Current:** 100 mA

3.5.3.4 COM Port

- **Port Type:** RS-485
- **Baud Rate (bps):** 1200, 2400, 4800, 9600, 19200, 38400, 57600, 115200
- **Data Bits:** 7, 8
- **Stop Bits:** 1, 2
- **Parity:** None, Odd, Even
- **Flow Control:** Auto flow control
- **Signals:** DATA+ and DATA-
- **Protection:** 15 kV ESD
- **Supported Protocols:** Modbus/RTU (Up to 128 addresses with a maximum of 30 instructions)

3.5.4 WISE-S672 I/O Module

3.5.4.1 Digital Inputs

- **Channels:** 6
- **Logic Level (Dry Contact):**
 - 0: Open
 - 1: Close DI COM
- Non-isolation
- Supports 32-bit counter input function (maximum signal frequency: 200 Hz)
- Supports keep/discard counter value when power OFF
- Supports frequency input function (maximum signal frequency: 200 Hz)
- Supports inverted digital input status

3.5.4.2 COM Port #1

- **Port Type:** RS-485
- **Baud Rate (bps):** 1200, 2400, 4800, 9600, 19200, 38400, 57600, 115200
- **Data Bits:** 7, 8
- **Stop Bits:** 1, 2
- **Parity:** None, Odd, Even
- **Flow Control:** Auto flow control
- **Signals:** DATA+ and DATA-
- **Protection:** 15 kV ESD
- **Supported Protocols:** Modbus/RTU (Up to 32 addresses with a maximum of 8 instructions)

3.5.4.3 COM Port #2

- **Port Type:** RS-485 or RS-232
- **Baud Rate (bps):** 1200, 2400, 4800, 9600, 19200, 38400, 57600, 115200
- **Data Bits:** 7, 8
- **Stop Bits:** 1, 2
- **Parity:** None, Odd, Even
- **Flow Control:** Auto flow control (RS-485 only)
- **Signals:** DATA+ and DATA-
- **Protection:** 15 kV ESD
- **Supported Protocols:** Modbus/RTU (Up to 32 addresses with a maximum of 8 instructions)

3.6 I/O Pin Assignment

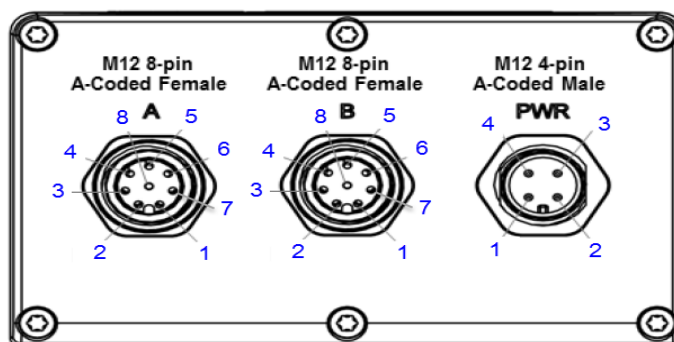
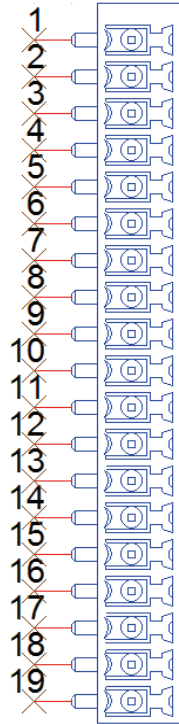

Figure 3.1 WISE-S600 Pin Out

Table 3.1: I/O Pin Assignment

Model Name	M12 Cable	WISE-S672	WISE-S614	WISE-S615	WISE-S617	
Pin Number						
PCB P/N	4Pin: 1700028162-01 8Pin: 1700028163-01	19A3DC7200-01	19A3DB1402-01	19A3DC1500-01	19A3DC1700-01	
Version		A101-1 (M/P)	A101-3 (M/P)	A101-1 (ES1)	A101-1 (ES1)	
A	1	White	DI 0	DI 0	RTD0+	AI 0+
	2	Brown	DI 1	DI 1	RTD0-	AI 0-
	3	Green	DI 2	DI 2	RTD0 COM	+12V Out0
	4	Yellow	DI 3	DI 3	NC	+12V Out GND
	5	Gray	DI 4	NC	RTD1+	AI 1+
	6	Pink	DI 5	NC	RTD1-	AI 1-
	7	Blue	NC	NC	RTD1 COM	+12V Out1
	8	Red	DI COM	DI COM	NC	+12V Out GND
B	1	White	DATA0-	AI 0+	RTD2+	DI 0
	2	Brown	DATA0+	AI 0-	RTD2-	DI 1
	3	Green	RS-232 TX	AI 1+	RTD2 COM	DI COM
	4	Yellow	RS-232 RX	AI 1-	NC	DO 0
	5	Gray	DATA1-	AI 2+	RTD3+	DO GND
	6	Pink	DATA1+	AI 2-	RTD3-	RS-485 D+
	7	Blue	NC	AI 3+	RTD3 COM	RS-485 D-
	8	Red	RS-232 GND	AI 3-	NC	RS-485 GND
PWR	1	Brown	+VS	+VS	+VS	+VS
	2	White	-VS	-VS	-VS	-VS
	3	Blue	SP+	SP+	SP+	SP+
	4	Black	NC	SP-	SP-	SP-
	Gray (NC)					

3.7 Pin Assignment of WISE-S600T I/O Module with Terminal Block Connectors



Update Date			2020/3/16
Model Name	WISE-S614T	WISE-S617T	WISE-S615T
PCB P/N	19A3DC1410-01	19A3DC1710-01	19A3DC1710-01
Version	A101-1	A101-1	A101-1
Power In	Line Power, Panel in	Line Power, Panel in	Line Power, Panel in
I/O Description	4*AI, 4*DI	2*DI, 1*DO, 1*RS-485, 2*AI, 2*12V_output	4*RTD
1	DI 0	AI 0+	RTD 0+
2	DI 1	AI 0-	RTD 0-
3	DI 2	AI 1+	COM 0
4	DI 3	AI 1-	RTD 1+
5	DI COM	VOUT 0	RTD 1-
6	AI 0+	VOUT GND	COM 1
7	AI 0-	VOUT 1	RTD 2+
8	AI 1+	VOUT GND	RTD 2-
9	AI 1-	DO 0	COM 2
10	AI 2+	DO GND	RTD 3+
11	AI 2-	DI 0	RTD 3-
12	AI 3+	DI 1	COM 3
13	AI 3-	DI COM	NC
14	NC	DATA+	NC
15	NC	DATA-	NC
16	NC	GND	NC
17	Panel In	Panel In	Panel In
18	+VS	+VS	+VS
19	-VS	-VS	-VS

3.8 Application Wiring of WISE-S600 I/O Module with M12 Connectors

3.8.1 WISE-S614 I/O Application Wiring

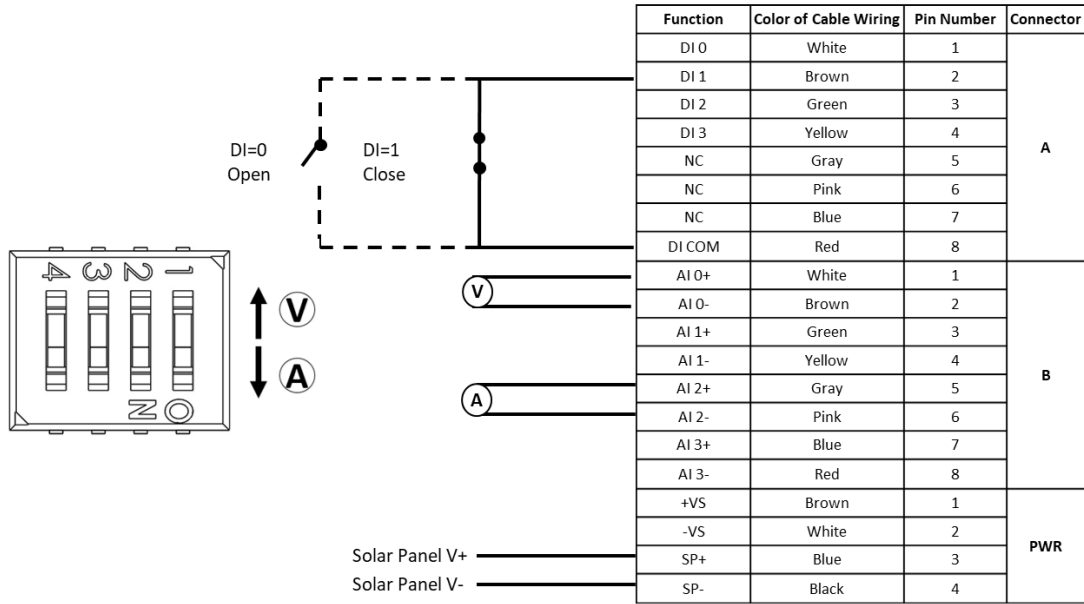

Figure 3.2 WISE-S614 I/O Application Wiring

3.8.2 WISE-S615 I/O Application Wiring

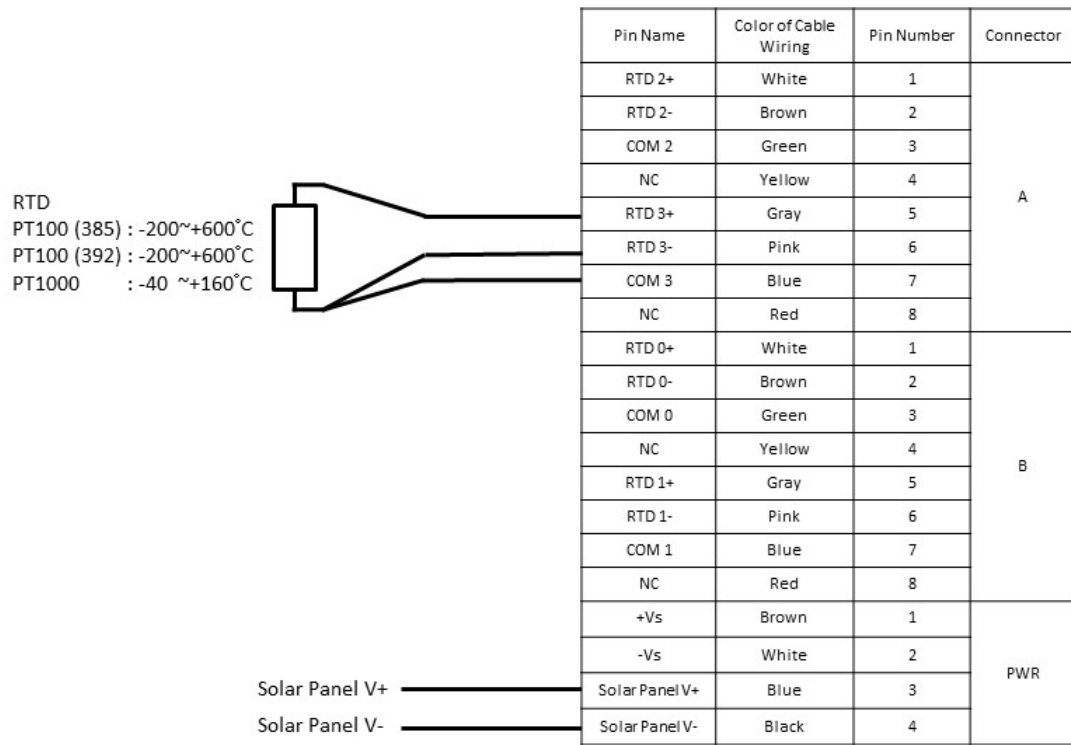

Figure 3.3 WISE-S615 I/O Application Wiring

3.8.3 WISE-S617 I/O Application Wiring

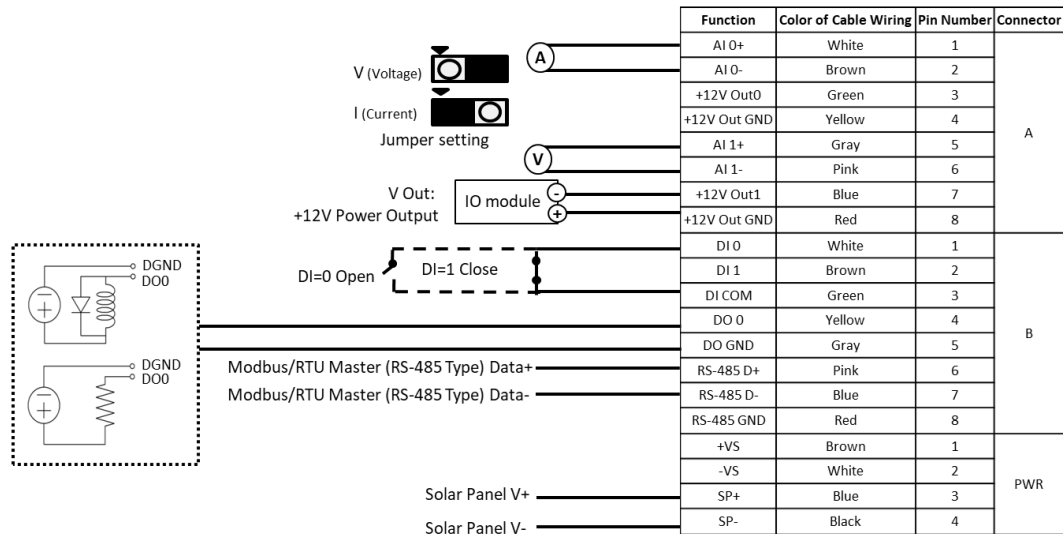

Figure 3.4 WISE-S617 I/O Application Wiring Diagram

3.8.4 WISE-S672 Application Wiring

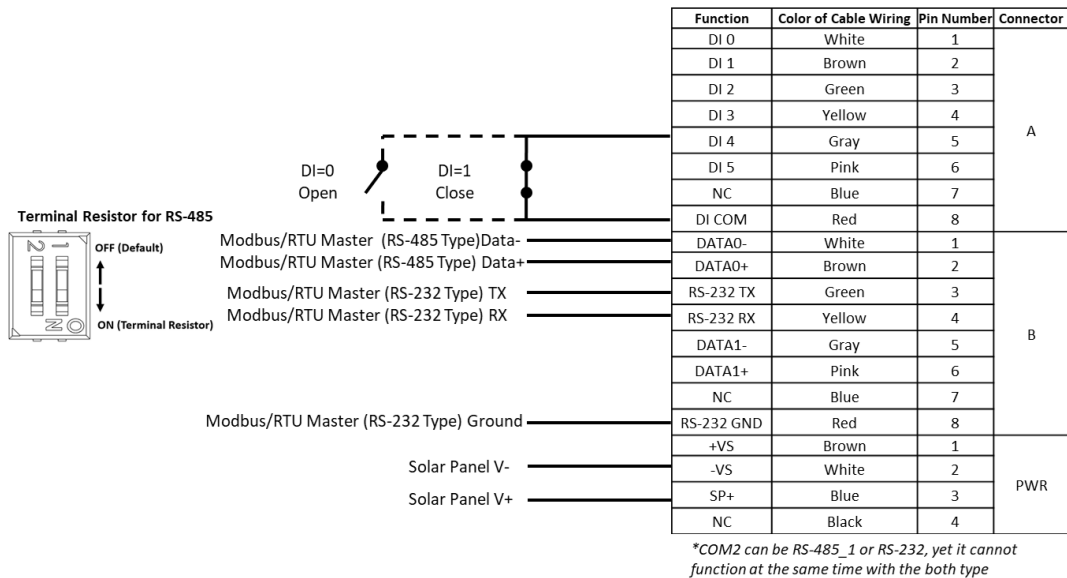

Figure 3.5 WISE-S672 Application Wiring Diagram

3.9 Application Wiring of WISE-S600T I/O Module with Terminal Block

3.9.1 WISE-S614T I/O Application Wiring

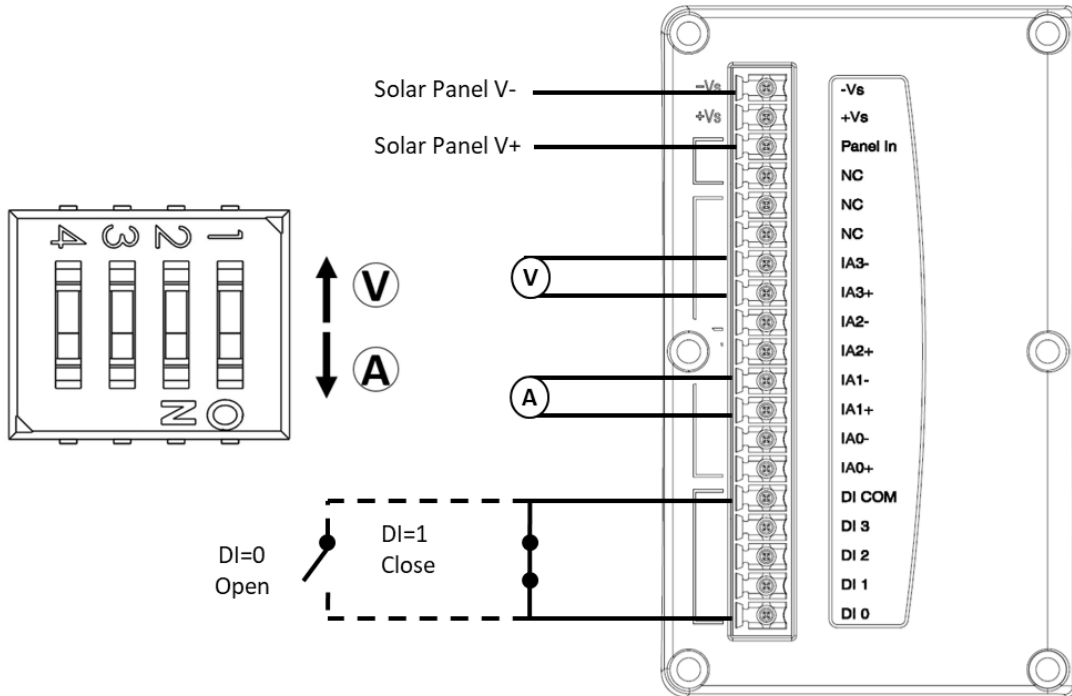

Figure 3.6 WISE-S614T I/O Application Wiring Diagram

3.9.2 WISE-S617T I/O Application Wiring

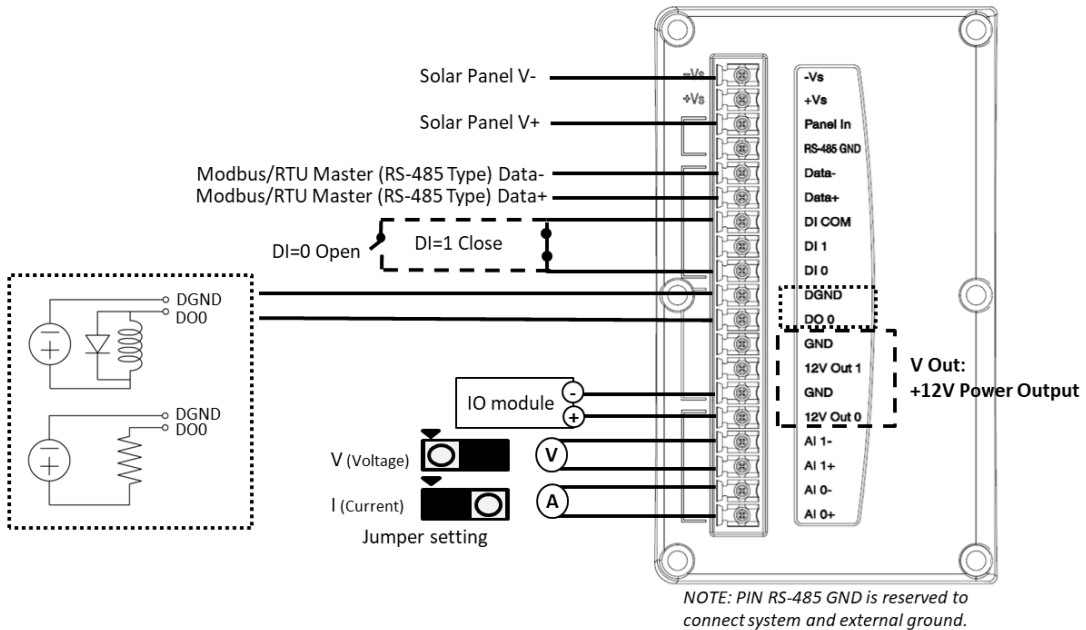

Figure 3.7 WISE-S617T I/O Application Wiring Diagram

3.10 Power Supply Wiring

WISE-4610 modules are designed to support a standard unregulated 24- V_{DC} industrial power supply. However, they can also accept 10 ~ 50 V_{DC} input with a peak-to-peak power ripple of 200 mV. The immediate ripple voltage should be maintained at 10 ~ 50 V_{DC} . The screw terminals labeled “+Vs” and “-Vs” are for the power supply wiring. Refer to Section 3.6 “I/O Pin Assignment” for more details.

3.11 Block Diagram

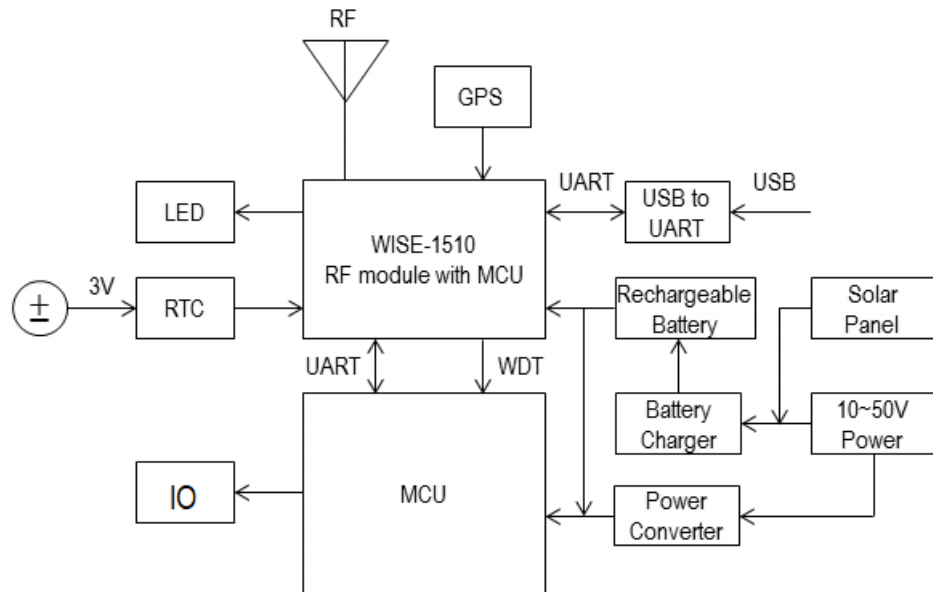

Figure 3.8 WISE-4610 Block Diagram

3.12 Configuration Interface

- **Interface:** USB virtual COM port
- **Connector:** Micro-B USB
- **USB Chipset:** Silicon Labs CP210x
- **Driver:** CP210x USB-to-UART bridge VCP drivers

Chapter 4

Software Functions

4.1 System Structure

LoRaWAN (Long Range Wide Area Network) system structure consists of several key components that work together to enable long-range communication between IoT devices. Here's an overview:

1. End Devices (WISE-4610)
 - Function: WISE-4610 Industrial Wireless I/O solution can connect to any kinds of sensors or meters to collect data, such as flow, pressure, level, energy usage for different kinds of applications
 - Communication: End devices use LoRa modulation to send data to gateways.

2. Gateways (WISE-6610)
 - Function: Gateways act as a bridge between the end devices and the network server. They receive LoRa-modulated signals from the end devices and forward them to the network server via a standard IP connection (e.g., Ethernet or cellular).
 - Communication: Gateways are typically connected to the network server through a high-bandwidth connection, allowing them to handle multiple data streams from various devices simultaneously.

3. Network Server (Embedded in WISE-6610)
 - Function: The network server manages the network, ensuring that data is correctly routed between end devices and the application server. It handles tasks such as:
 - De-duplication: Ensuring only one copy of a message is processed if multiple gateways receive the same message.
 - Security: Managing encryption keys and ensuring secure data transmission.
 - Device Management: Tracking all devices, their status, and configuration.

4. Application Server
 - Function: The application server processes data received from the end devices via the network server. It interprets this data, making it available for applications, dashboards, or triggering other actions (e.g., sending alerts).
 - Communication: The application server communicates with the network server to receive data and can send commands back to the devices if necessary.

This structure enables LoRaWAN to provide long-range, low-power communication, making it ideal for various IoT applications, including smart cities, agriculture, and industrial monitoring.

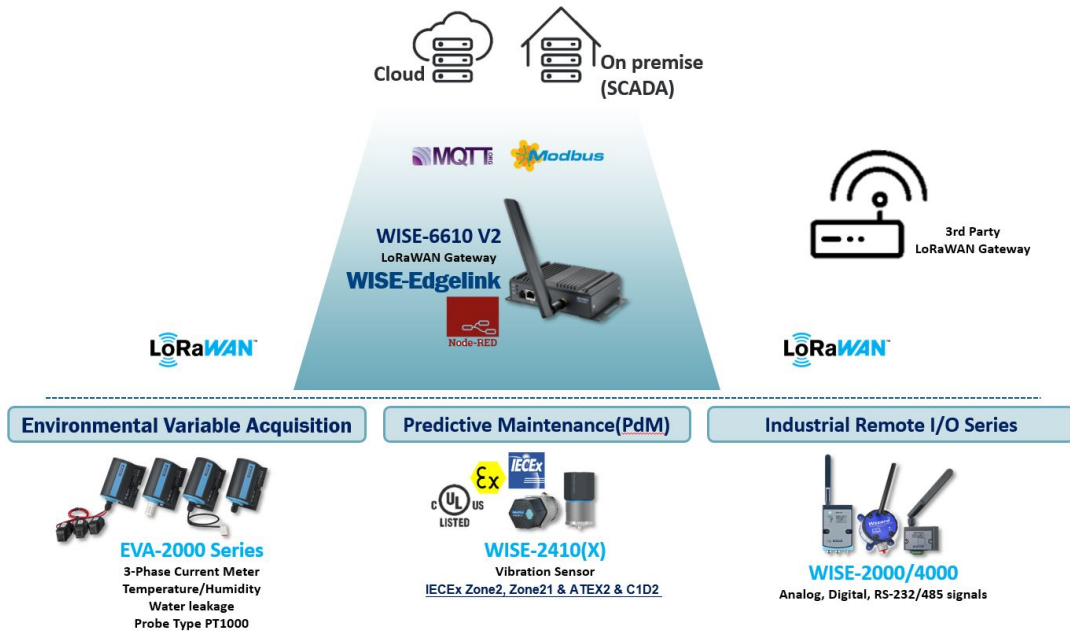

4.2 Interface Design

4.2.1 LoRaWAN Functions

WISE-4610 can be configured via WISE-Studio to establish a LoRaWAN.

Table 4.1: LoRaWAN Functions

Item	Description
Device Operating Mode	LoRaWAN
Device Class	(Default: 1) 1: Class A 3: Class C
Activation Mode	(Default: 2) 1: OTAA (Over-The-Air Activation) 2: ABP (Activation By Personalization)
Port Field (FPort)	FPort values 1.223 (0x01.0xDF) are application-specific and any received frames with such an FPort SHALL be made available to the application layer by the LoRaWAN implementation.
Data Message Confirmed	1: Configure the module to send data message confirmations that must be acknowledged by the receiver. 0: Unconfirmed data messages.
Application Identifier (AppEUI), if OTAA	AppEUI is a global application ID in IEEE EUI64 address space that uniquely identifies the entity able to process the JoinReq frame. AppEUI is stored in the end-device before the activation procedure is executed. (Length: 8 bytes)
Application Key (AppKey), if OTAA	AppKey is an AES-128 root key specific to the end-device. Whenever an end-device joins a network via over-the-air activation, the AppKey is used to derive the NwkSKey and AppSKey session keys specific to that end-device for encrypting and verifying the network communication and application data. (Length: 16 bytes)
Network Session Key (NwkSkey), if ABP	The NwkSKey is a network session key specific for the end-device. It is used by both the network server and the end-device to calculate and verify the MIC (message integrity code) of all data messages to ensure data integrity. It is also used to encrypt and decrypt the payload field of MAC-only data messages. (Length: 16 bytes)
Application Session Key (AppSKey), if ABP	The AppSKey is an application session key specific to the end-device. It is used by both the application server and the end-device to encrypt and decrypt the payload field of application-specific data messages. (Length: 16 bytes)

Table 4.2: Configuration Parameters for LoRaWAN

	OTAA	ABP
Globally Unique End-Device Identifier (DevEUI)	√	
Device Address (DevAddr)		√
Application Identifier (AppEUI)	√	
Application key (AppKey)	√	
Network Session Key (NwkSkey)		√
Application Session Key (AppSKey)		√

4.2.2 Positioning

4.2.2.1 General Description

WISE-4610 accesses the u-blox EVA-M8M-0 GNSS module via the I2C interface. This GNSS module can provide geolocation and time information.

The features of EVA-M8M are listed below:

Table 4.3: Features	
Receiver Type	72-channel u-blox M8 engine GPS/QZSS L1 C/A, GLONASS L10F, BeiDou B1 SBAS L1 C/A: WAAS, EGNOS, MSAS Galileo-ready E1B/C
Maximum Navigation Update Rate	Single GNSS: Up to 18 Hz Concurrent GNSS: Up to 10 Hz
Accuracy	Position: 2.5 m CEP SBAS: 2.0 m CEP
Acquisition	Cold starts: 27 s Aided starts: 4 s Reacquisition: 1 s
Sensitivity	Tracking and navigation: -164 dBm Cold starts: -147 dBm Hot starts: -156 dBm
Assistance GNSS	AssistNow Online AssistNow Offline AssistNow autonomous OMA SUPL and 3GPP compliant

■ Measurement Data

The data below is available from the GNSS module:

Table 4.4: Measurement Data		
	Values	Description
UTC Time	2017~	Year
	1 ~ 12	Month
	1 ~ 31	Day
	0 ~ 23	Hour
	0 ~ 59	Minute
	0 ~ 59	Second
Position	Longitude	(+/- *10 ⁻⁷ degree), a minus sign if south of the equator
	Latitude	(+/- *10 ⁻⁷ degree), a minus sign if west of the prime meridian
	Altitude	(*10 ⁻³ m) height above mean sea level
	Speed	(*10 ⁻³ km/hr) ground speed
	Number of satellites	Satellites used for navigation

- Configurations

Table 4.5: Configurations

Item	Description	
Positioning Enable/Disable	Enable or disable the GNSS module. (Default: Disable)	
Position Update Period	Time between two position fix attempts (15 sec ~ 1 day, unit: second) (Default: 1 hr)	
Select Permissible GNSS System	Specify which GNSS signals should be processed	
	Value	GNSS combination
	0	(Reserved)
	1	GPS + GLONASS (default)
	2	GPS + Galileo
	3	Galileo + GLONASS
	4	GPS + Galileo + GLONASS
	5	GPS + BeiDou
	6	Galileo + BeiDou
	7	GPS + Galileo + BeiDou
8	GLONASS + BeiDou	
*If GPS is enabled, SBAS and QZSS will also be enabled by default.		

4.2.3 LED Indicator Behaviors

- All LED indicators will turn OFF automatically after 15 seconds when the module is using battery power.

Table 4.6: LED Indicator Behaviors

LED	Color	State	Description
Status	Green	Fast blink (0.2 sec ON, 0.3 sec OFF)	Waiting for connection or connecting
		Slow blink (0.2 sec ON, 1.8 sec OFF)	Connecting and operating normally
Error	Red	Fast blink (0.2 sec ON, 0.8 sec OFF)	Application errors. (*Note 1) <ul style="list-style-type: none"> ■ Network registration timeout ■ I/O Error ■ FW error
		Slow blink (0.2 sec ON, 2.8 sec OFF)	<ul style="list-style-type: none"> ■ Low battery voltage ($v \leq 20\%$) ■ Low RTC battery voltage ■ Battery internal short is detected
		Off	No error
RF RX	Green	On (0.2 sec ON)	Received data from Gateway
		Off	Idle
RF TX	Yellow	On	Sending data to gateway
		Off	Idle
Signal Strength	4 Green	On (if pressing the membrane button)	Main battery capacity <ul style="list-style-type: none"> ■ All OFF - $V \leq 20\%$ ■ 1 ON - $20\% < V < 40\%$ ■ 2 ON - $40\% \leq V < 60\%$ ■ 3 ON - $60\% \leq V < 80\%$ ■ 4 ON - $V \geq 80\%$

*Note 1

Table 4.7:

Error LED	Signal LEDs				Description	
	1st (poor)	2nd (Okay)	3rd (Good)	4th (Full)		
Error		OFF	OFF	OFF	Fast Blink RF related Error	
	Fast Blink	OFF	OFF	Fast Blink	OFF	I/O Error
		OFF	OFF	OFF	OFF	FW error
	Slow Blink	OFF	OFF	OFF	OFF	Battery related Error
	OFF	OFF	OFF	OFF	OFF	No error

4.2.4 Battery Charging

The battery IC serves as a gauge for estimating the remaining battery capacity.

Table 4.8:

Items	Values	Description
Remaining Battery Capacity	0 ~ 100%	An unsigned integer value of the predicted remaining battery capacity expressed as a percentage of full-charge capacity, with a range of 0 to 100%.
Cycle Count	0 ~ 65535	An unsigned integer value of the number of cycles the battery has undergone
Temperature	°C	An unsigned integer value of the battery temperature in units of 0.01 °C. * Temperature: 0x06/0x07 command used. It should be the external thermistor temperature.

Table 4.9:

		Flag Bit Definitions	
		Bit	Content
		15	OTC
		14	OTD
		13	BATHI
		12	BATLOW
		11	CHG_INH
		10	RSVD
		9	FC
		8	CHG
		7	OCVTAKEN
		6	ISD
		5	TDD
		4	HW1
		3	HW0
Operating Status	Flags	2	SOC1
		1	SOCF
		0	DSG

OTC = Over Temperature in Charge condition detected. True when set.
 OTD = Over Temperature in Discharge condition detected. True when set.
 BATHI = Battery High bit, indicating a high battery voltage condition.
 BATLOW = Battery Low bit, indicating a low battery voltage condition.
 CHG_INH = Charge Inhibit indicates the temperature is outside the range [Charge Inhibit Temp Low, Charge Inhibit Temp High]. True when set.
 FC = Fully charged condition reached (RMFCC = 1; Set. FC_Set% = -1% when RMFCC = 0). True when set.
 CHG = (Fast) charging allowed. True when set.
 OCVTAKEN = Cleared when switched to Relax mode, and set to 1 when OCV measurement is performed in Relax mode.
 ISD = Internal Short is detected. True when set.
 TDD = Tab Disconnect is detected. True when set.
 HW [1:0] Device Identification. Default is 01.
 SOC1 = State-of-Charge Threshold 1 (SOC1 Set) reached. True when set.
 SOCF = State-of-Charge Threshold Final (SOCF Set%) reached. True when set.
 DSG = Discharging detected. True when set.

■ Battery Events

Table 4.10: Battery Events

Events	Condition	Error LED (Slow Blink)
Low voltage	Remaining battery capacity <= 20%	V
Over Temperature in Charge condition detected	Battery temperature < 0 °C or > 60 °C	
Over Temperature in Discharge condition detected	OTD flag of Operating Status set	
Internal Short detected	ISD flag of Operating Status set	V
Fully charged condition reached	FC flag of Operating Status set	

- Battery Temperature and Charging

Table 4.11: Battery Temperature and Charging

	Battery Temp. T (°C)	Battery Level %	Charging
1	$T < 0$	-	Stop charging
2	$0 \leq T \leq 45$	-	Allow charging
3	$45 < T \leq 60$	$> 10\%$	Stop charging
		$\leq 10\%$	Charge to 20% only
4	$T > 60$	-	Stop charging

4.2.5 Membrane Button

Refer to Section 4.2.3 “LED Indicator Behaviors” for detailed information regarding the membrane button functionality:

- In the “DC Power Only” or “DC Power and Battery” modes, when WISE-4610 is powered via the power cable:
 1. The LED indicators are turned OFF as the default setting.
 2. To check the battery capacity, press the membrane button to light up the battery capacity indicator.
 3. Press the membrane button again to turn OFF the LED indicators and revert to State 1.
 4. If the power cable is removed and WISE-4610 is powered by the battery, the module will enter “Battery Power Only” mode.
- In “Battery Power Only” mode:
 1. The LED indicators are turned OFF as the default setting. The Status/Error/Rx/Tx/COM LEDs will light up for 15 seconds only.
 2. In State 1, all LED indicators will automatically turn OFF after 15 seconds to save power.
 3. In State 1, when the membrane button is pressed, all LED indicators, including the four battery capacity indicators, will light up. The indicators will automatically turn OFF after 15 seconds.
 4. In State 3, press the membrane button again to turn OFF the LED indicators.
 5. When all LED indicators are not illuminated, press the membrane button again to revert to State 1.
 6. When connected to the power supply cable, WISE-4610 will enter either the “DC Power Only” or “DC Power and Battery” modes.

4.2.6 Multiple Power Sources

WISE-4610 is compatible with three sources of power: batteries, DC power, and solar panels. The power source detection, power fail (remove cable and solar power), low-battery, and suspend LEDs will vary depending on the power source:

- Low-Battery Indicator - When the remaining battery capacity is 20% or less, the low-battery LED will blink slowly.
- Low-Battery Suspend - When the remaining battery capacity is 10% or less, module operations will be suspended.

Table 4.12:

Power Combination				Module Features				
DC Power	Solar Panel	Battery		Power source detection	Power fail (remove cable and solar panel)	Low battery		
			Switch			Error LED	Suspend	
Y	Y	Y	ON	Cable, battery	No PF signal, system running	Slow blink if $\leq 20\%$	No	
			OFF		PF			
		N		Cable	PF			
	N	Y	Y	ON	Cable, battery	No PF signal, system running	Slow blink if $\leq 20\%$	No
				OFF		PF		
		N		Cable	PF			
N	Y	Y	ON	Solar panel, battery	No PF signal, system running	Slow blink if $\leq 20\%$	No	
			OFF		PF			
		N		Solar panel	PF			
	N	Y	Y	ON	Battery	No PF signal (battery cannot be removed)	Slow blink if $\leq 20\%$	Suspend if $\leq 10\%$
				OFF		Module is not working		
		N						

Table 4.13:

Power Cable (DC/Panel)	Battery Power		Action	Keep counter values
		Switch		
Y	N		Remove power cable	Yes
Y	Y	ON	Remove power cable	Based on battery level
		OFF		No
N	Y	ON	Switch ON→OFF	No

4.3 Connection Setting on WISE-4610

- Configure the WISE-4610 module using WISE-Studio through a USB port.

4.3.1 Configure WISE-4610 by Using WISE-Studio

4.3.1.1 Minimum System Requirements

The minimum system requirements for WISE-Studio are as follows:

- Microsoft Windows 7 or later
- Microsoft .NET framework 3.5 or later
- Internet Explorer 10 or later

4.3.1.2 Installing WISE-Studio

The latest version of WISE-Studio is available on the Advantech support website <http://support.advantech.com/>. To install the software, download the installation file and execute it locally.

4.3.1.3 Introduction to WISE-Studio

WISE-Studio is a tool for configuring WISE modules. The software provides a web-based interface that is similar for different models. For WISE modules configured via Ethernet, LAN, or WLAN, WISE-Studio enables communication with the WISE module's internal web server. For modules configured via USB, WISE-Studio executes a web server on the computer installed with the software. The web server then uses the USB interface to communicate with the WISE module. The module information can be accessed via the embedded web page or a web browsers.

Communication Box

In this box, there are several communication interfaces for configuring various WISE modules. The WISE-4610 series uses the USB serial interface for configuration.

Refresh: Pressing this button refreshes the USB serial interface.

USB-Serial: This block is for connecting to a WISE module via USB. The available USB serial port number will be shown here. Click **Go to Configuration** to connect the USB COM port.

USB-Serial Configuration Page

After clicking **Go to Configuration**, all available USB COM ports will be displayed.

Choose the COM port to configure and click **Connect** to open the **Configuration** page. Users can also click **Open in Browser** to use your default browser to configure the WISE module (IE is the default browser embedded in WISE-Studio).

4.3.1.4 Information Page

Module Information

This page displays the name of the module and related information. Click **Go to Configuration** to view or change the settings.

Model Name: Model of WISE module

Customized Name/UUID: Refer to the model name and UUID of the module.

The default UUID is a combination of the model name and IMEI. Users can modify this value.

Location Information: The module location is provided here.

Description: Any comments about the module can be displayed here.

Power Status displays the power source and battery status.

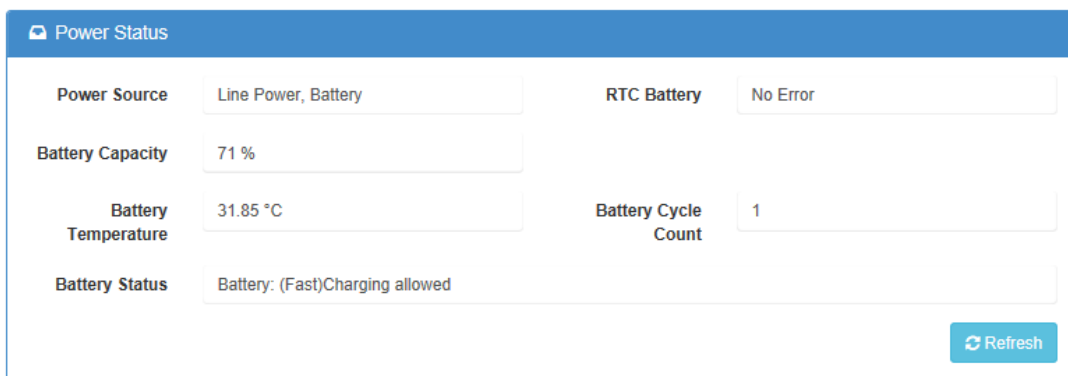

The screenshot shows a 'Power Status' page with a blue header. It contains several data fields in a grid layout:

Power Source	Line Power, Battery	RTC Battery	No Error
Battery Capacity	71 %		
Battery Temperature	31.85 °C	Battery Cycle Count	1
Battery Status	Battery: (Fast)Charging allowed		

A 'Refresh' button is located at the bottom right of the page.

Device Information lists the module firmware and web page version.

On this page, users can obtain the WISE module coordinates.

Configuration

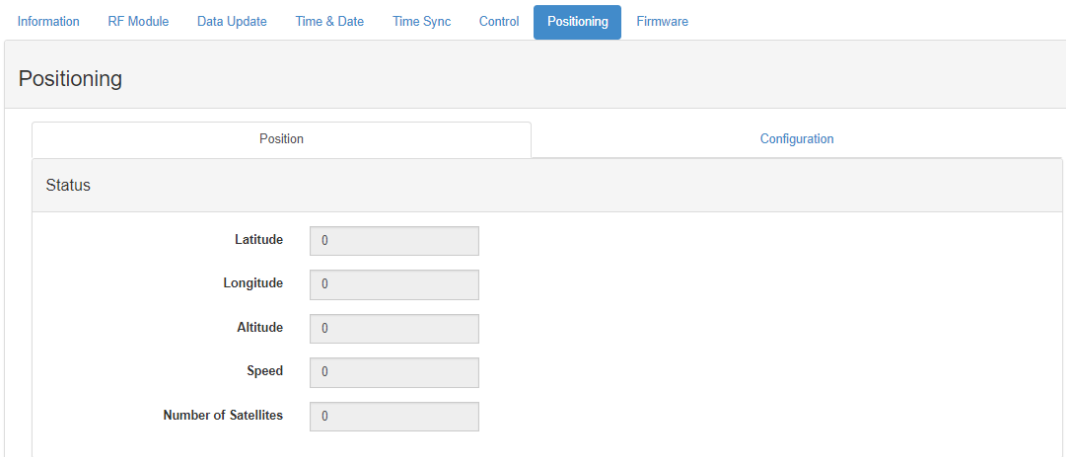

The screenshot shows the 'Configuration' page with a navigation bar at the top containing 'Information', 'RF Module', 'Data Update', 'Time & Date', 'Time Sync', 'Control', 'Positioning', and 'Firmware'. The 'Positioning' tab is selected. Below the navigation bar, there are two tabs: 'Position' and 'Configuration'. The 'Position' tab is active, showing a 'Status' section with the following fields:

Latitude	0
Longitude	0
Altitude	0
Speed	0
Number of Satellites	0

The WISE-4610 module is equipped with GPS. The options on this page allow users to enable/disable GPS positioning. To save power, GPS is disabled by default. Moreover, users can configure the specific update interval.

As shown below, the **GNSS System** field features a dropdown menu with different GPS system combination options. Users can select the system combination according to their usage requirements.

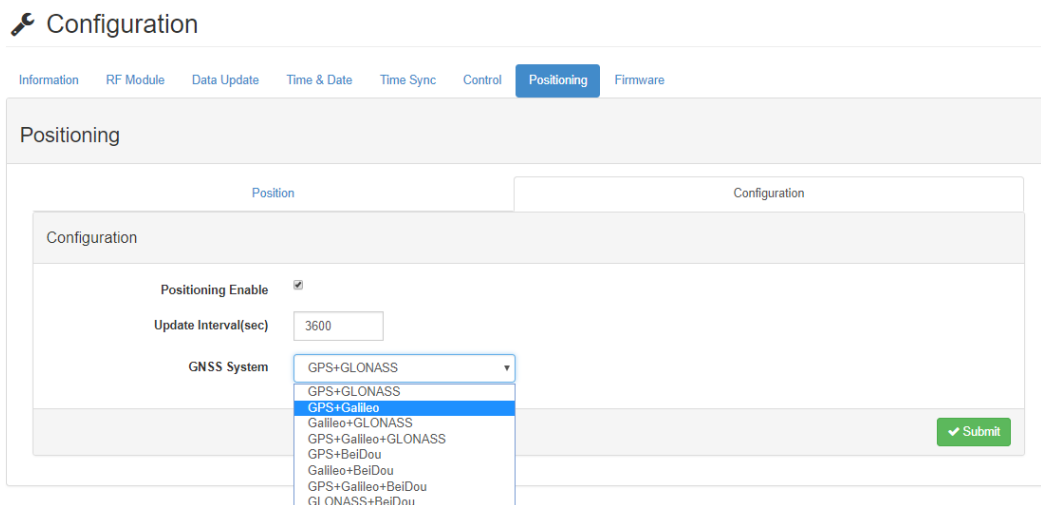

4.3.1.5 I/O Status Configuration

Digital Input

Status

The value of all digital input channels can be determined from the LED indicators on the DI tab (green LED = logic high; grey LED = logic low).

IO Status

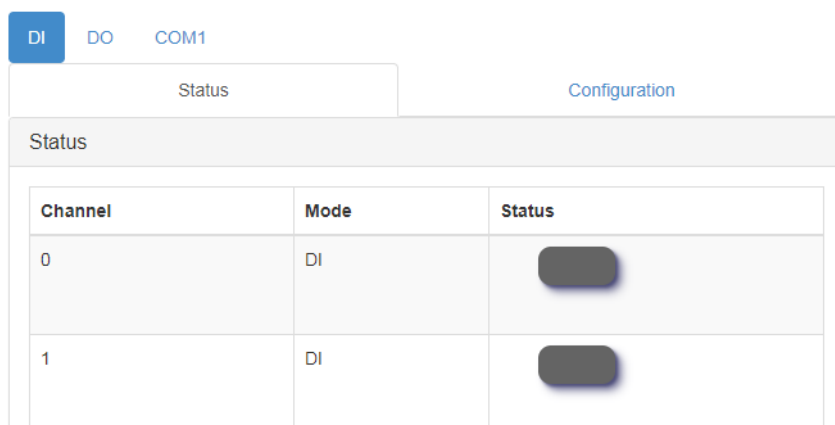

Configuration

The digital input channels support several operation modes and can be configured from this page.

- **Channel:** Select the channel to be configured.
- **Tag Name:** Each channel can be given a name for identification.
- **Mode:** This item allows users to configure the operating mode for each channel. Channels can also be disabled/enabled to improve the overall performance. After a channel has been configured, click **Submit** at the bottom of this page to implement the changes.
- **Channel Mask:** Each channel can be disabled individually to reduce data communication traffic.
- **Refresh:** This item allows users to refresh the system configuration settings.

The screenshot shows a web interface with a navigation bar at the top containing 'DI', 'DO', and 'COM1'. Below this is a tabbed interface with 'Status' and 'Configuration' tabs. The 'Configuration' tab is active, showing a form with the following fields:

- Channel:** A dropdown menu with '0' selected.
- Tag Name:** A text input field containing 'W4471_047604-DI0'.
- Mode:** A dropdown menu with 'DI' selected.
- Channel Mask:** A checkbox labeled 'Enabled/Disabled' which is checked.
- Refresh:** A blue button with a circular arrow icon and the text 'Refresh'.

Below the 'Mode' dropdown, there is a small information icon and the text: 'Channel Mode is used for Channel Status Display only.'

- **Invert Signal:** WISE digital input channels support inverted digital input status. To enable/disable this function, click the **Invert Signal** check box on the Configuration page.
- **Digital Filter:** Digital input channels have a digital filter that can remove high-frequency noise. The filter can be enabled/disabled by clicking the **Digital Filter** check box. When the filter is enabled, the minimum acceptable signal width can be defined in the **Min. Low Signal Width** and **Min. High Signal Width** fields (increment: 0.1 ms).

The screenshot shows a configuration section titled 'Invert Signal' with a checkbox labeled 'Enabled/Disabled' which is unchecked. Below this is a section titled 'Digital Filter' with a checkbox labeled 'Enabled/Disabled' which is unchecked. Under the 'Digital Filter' section, there are two input fields:

- Min. Low Signal Width:** A text input field containing '1' and a unit label '0.1ms'.
- Min. High Signal Width:** A text input field containing '1' and a unit label '0.1ms'.

- **Counter:** When counter mode is selected for a given channel, the number of pulses in the digital signal from that channel are counted and recorded to the register. On the **Status** page, the current count value of the selected channel is displayed in the **Counter Value** field. The counter can be started/stopped by pressing **Start/Stop**. The counter can be reset (the value stored in the register will be reset to the default, which is zero) by clicking **Reset**. The predefined startup value is the value shown in the **Counter value** field. When this is reset, either by pressing **Reset** on the **Status** page or by issuing a command, the default settings will be restored (the default value for this field is zero). If **Keep Last Value** is enabled, the last counter value will be retained in the register when the module is powered OFF. When the module is powered ON, the counter will continue to count from that value. When this function is disabled, powering off the module will cause the counter to be reset and the count value in the register to be reset to zero.
- **Frequency:** For pure digital input channels, WISE modules support frequency mode, which calculates the frequency of the digital input signal of the selected channel. The frequency value will be displayed in the **Frequency value** field on the DI Status page. The **Precision** settings can be configured to specify the frequency for different input ranges. The **Value Reset Time** function allows users to specify when the frequency value is reset to zero if the pulse bandwidth is greater than expected.

The screenshot shows a configuration interface with the following elements:

- Counter: Startup Value:** A text input field containing the number "0" and a "times" label to its right.
- Counter: Keep Last Value:** A checkbox that is currently unchecked, with the text "Enabled/Disabled" to its right.
- Frequency: Precision:** A dropdown menu currently showing "0.1 Hz".
- Frequency: Value Reset Time:** A text input field containing the number "100" and a "0.1 sec" label to its right.
- Submit:** A green button with a checkmark icon and the text "Submit" located at the bottom right of the form.

- **Low-to-High Latch:** Under low-to-high latch mode, once a digital input channel detects that the logic level has changed from low to high, the logic status will remain as “logic high” until the latch is cleared manually, which will return the logic status to “logic low”. The logic status can be determined via the latch status LED included on the **DI Status** page. Clear the latch by clicking **Clear**.
- **High-to-Low Latch:** Under high-to-low latch mode, once a digital input channel detects that the logic level has changed from high to low, the logic status will remain as “logic low” until the latch is cleared manually, which will return the logic status to “logic high”. The logic status can be determined via the latch status LED included on the **DI Status** page. Clear the latch by clicking **Clear**.

IO Status

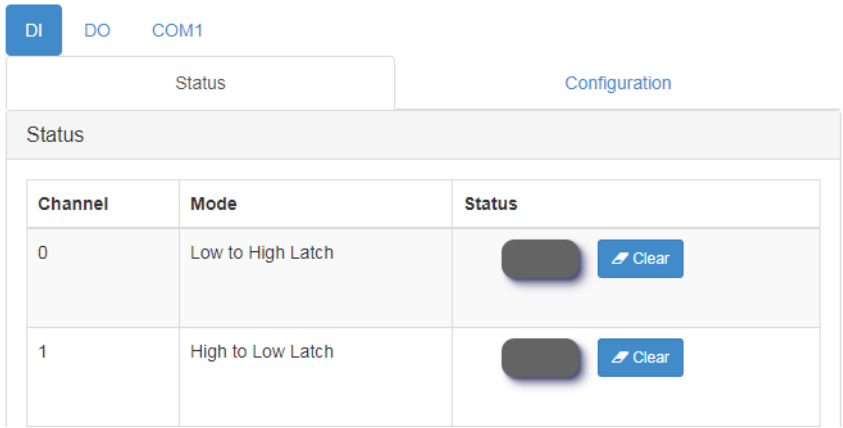

Channel	Mode	Status
0	Low to High Latch	<input type="checkbox"/> Clear
1	High to Low Latch	<input type="checkbox"/> Clear

COM1 (RS-485 Port)

WISE-4610 features one RS-485 port for Modbus gateway functionality. This port can be used to poll data from RS-485 Modbus/RTU slave devices, such as Advantech’s ADAM-4000 or ADAM-5000/485 series devices.

Status

Navigate to the **COM1** tab to check the status or configure the RS-485 Modbus master function. A total of 32 Modbus slave addresses can be mapped as the WISE module I/O. These 32 addresses can be coils or registers; coils will be mapped as extension bits of the WISE module, and registers will be mapped as extension words of the WISE module. In the **COM1** status tab, the bits and words are shown on individual pages.

- **Channel:** Indicates the number of bits. A maximum of 32 bits can be displayed, but less than 32 coils can be mapped as bits. The empty bits are invalid. The same applies to words, which may also have empty channels.
- **Value:** This shows the value polled from mapped addresses.
- **Status:** This shows the status of each bit or word. If a channel is empty or has not been mapped to a Modbus slave address, the status will be “Unavailable”.
- **Slave ID:** This is the Modbus slave ID of RS-485 Modbus slave devices.
- **Slave Address:** This is the address of a bit or word from an RS-485 Modbus slave device.

For a writable bit or word, users can click **Edit** to switch to edit mode to change the value. Then click **Apply** to write the Modbus addresses individually.

IO Status

The screenshot shows the 'IO Status' interface with the 'COM1' tab selected. Below the tab are three sub-tabs: 'Status', 'Modbus/RTU Configuration', and 'Diagnostician'. The 'Status' sub-tab is active, showing 'Bit Status' and 'Word Status' options. A 'Show 16 entries' dropdown and an 'Edit' button are visible. Below this is a table with the following data:

Channel	Value	Status	Slave ID	Slave Address
0		Unavailable	0	0

Modbus Configuration - Common Settings Tab

The options on this tab allow users to configure the RS-485 port parameters.

- **Baud Rate:** 1200, 2400, 4800, 9600, 19200, 38400, 57600, 115200 bps
- **Data Bit:** 7, 8
- **Stop Bit:** 1, 2
- **Parity:** None, Odd, Even
- **Slave Response Timeout:** This item allows users to specify the response time for Modbus slaves.
- **Delay Between Polls:** This item allows users to set the delay time between each Modbus instruction.
- **CRC Check:** This item allows users to set the CRC check to ignore Modbus CRC errors.

The screenshot shows the 'Modbus/RTU Configuration' interface with the 'Common Setting' tab selected. The 'Rule Setting' tab is also visible. The 'Common Setting' tab contains the following configuration options:

- Baud rate:** 9600 bps
- Data Bit:** 8 bit
- Parity:** None
- Stop Bit:** 1 bit
- Slave response timeout:** 50 ms
- Delay between Polls:** 10 ms
- CRC Check:** Disable Enable

A green 'Submit' button is located at the bottom right of the configuration area.

Modbus Configuration - Rule Setting Tab

The items on this tab allow users to configure the Modbus address of end devices to be polled.

- **Rule:** Each COM port can support a maximum of 8 rules. Each rule can be for a different slave device. This means a maximum 8 of devices can be connected to the COM port. Alternatively, all the rules can be used for polling different addresses on the same slave device.
- **Slave ID:** Each slave device connected to the RS-485 port has a unique slave ID. This item is the slave address of the Modbus devices connected to the WISE module.
- **Type:** This device supports Modbus data types: 01 Coil Status (0x), 02 Input Status (1x), 03 Holding Registers (4x), and 04 Input Registers (3x). After one of the types has been configured in the rule, the rule will be enabled and the COM port will start polling after the configuration has been implemented.
- **Start Address:** Enter the first address number to be polled. The address base is 1. To poll the first address of a holding register (i.e., 40001), simply input the number "1" (users do not need to input the entire address "40001").
- **Length:** Input the length of the address to be polled in this rule. For example, to poll 40001 ~ 40008, set the length as "8". Because each COM port can poll a maximum of 32 addresses, the maximum length is 32, and the total number of all rules should not exceed 32.
- **R/W:** This item allows users to set whether the address in this rule is read or written. For coil statuses and holding registers, users can configure these addresses as read-only or write-only to reduce the polling effort.
- **Scan Interval (unit: s):** This item allows users to set the scan interval for the COM port to poll Modbus slave devices. The COM port optimizes the scan interval according to the setting configuration. However, the read scan interval may depend on factors such as the Baud rate, slave device response time, and delay between polls. See the **Diagnostician** page to check the real response time as a reference for the scan interval value.
- **Mapping Channel:** When the Modbus address of slave devices is configured in each rule, these addresses are also mapped to the WISE module. the coils and registers of Modbus slave devices are mapped as bits for RESTful web service. There are 32 continuous channels of bits and another 32 continuous channels of words that can be mapped. Ensure that the channels for each rule do not overlap.
- **Log:** This item allows users to set whether the data polled from this rule is logged in the data logger.
- **Deviation/Change of Status (COS):** When this item is enabled, the difference between the current poll and last poll values can trigger a deviation/COS (change of state) for push data or log data.
- **Rule Status:** The web configuration interface will check whether the rule settings have any overlap or conflict. Rules can be enabled/disabled by setting the **Type** value. Enabled rules will be denoted with a green icon. The system will prompt users to confirm the submission of rules.

Note! After configuring the rules, click *Submit* to implement them.



Note!  After changing the rule configurations, the data logger is cleared of all data to accommodate the new data structure under the new configuration.

Note!  Move the mouse cursor over the table title rows to view tips.



 IO Status

DI DO **COM1**

Status Modbus/RTU Configuration Diagnostician

Modbus/RTU Configuration

Common Setting Rule Setting

Rule	Slave ID	Type	Start Address	Length	R/W	Scan Interval	Mapping Channel	Log	Deviation/COS	Deviation Value	Rule Status
0	1	Disable	1	1	R	60	0	<input checked="" type="checkbox"/>	<input type="checkbox"/>	3276	
1	1	Disable	1	1	R	60	0	<input checked="" type="checkbox"/>	<input type="checkbox"/>	3276	

Diagnostician

Because every device has a different response time, the WISE-4610 module supports a diagnostics function for testing the response time of each rule. This is intended to reduce the scan interval. Users can refer to the response time shown on this page when configuring the **Scan Interval** in the **Rule Setting** pages. The test results shown on this page can be reset by clicking **Reset Response Time**.

 IO Status

DI DO **COM1**

Status Modbus/RTU Configuration Diagnostician

Modbus/RTU Slave Response Time

Rule	Current Response Time(ms)	Max Response Time(ms)	Min Response Time(ms)	Status
0	0	0	65535	Unavailable
1	0	0	65535	Unavailable

4.3.1.6 System Configuration

Time & Date

WISE modules have a built-in RTC that allows users to view the current time, set the time zone, and adjust the time by pressing **Click Me** to read the time from host devices.

Control

- **Restore to Default:** This item allows users to clear the system configuration and restore all default settings.
- **System Restart:** This item reboots the module for a system restart.

Firmware

To update the firmware, go to the **Firmware** page in **System Configuration** and click the update file. The latest official firmware releases are available on the Advantech support website (<http://support.advantech.com/>). Users can also upload or export the configuration file.

Appendix **A**

Modbus Table with
WISE-4610

Table A.1: WISE-4610-S617 (for WISE-6610 LoRaWAN GW)

AI	2	DI	2	DO	1	Serial Port	1
Address 0X	Ch	Description	Attribute	Address 4X	Ch	Description	Attribute
00001	0	DI Value	Read	40017~40018	0	Counter/ Frequency Value	Read
00002	1		Read	40019~40020	1		Read
00033	0	Counter Start (1)/Stop(0)	R/W	40301	All	DI Value	Read
00034	1		R/W				
00041	0	Clear Counter (1)	Write				
00042	1		Write				
00049	0	Clear Overflow	R/W				
00050	1		R/W				
00057	0	DI L2H Latch Status	R/W				
00058	1		R/W				
00065	0	DI H2L Latch Status	R/W				
00066	1		R/W				
Address 0X	Ch	Description	Attribute	Address 4X	Ch	Description	Attribute
00017	0	DO Value	R/W	40303	All	DO Value	R/W
Address 0X	Ch	Description	Attribute	Address 4X	Ch	Description	Attribute
00101	0	Reset Historical Max. AI Value	Write	40001	0	AI Value	Read
00102	1		Write	40002	1		Read
00103	Average Ch 0~1		Write	40003	Average Ch 0~1		Read
00111	0	Reset Historical Min. AI Value	Write	40101~40102	0	*AI Status	Read
00112	1		Write	40103~40104	1		
00113	Average Ch 0~1		Write				
00131	0	AI High Alarm Flag	R/W	40111	0	Historical Max. AI Value	Read
00132	1		R/W	40112	1		Read
00133	Average Ch 0~1		R/W	40113	Average Ch 0~1		Read

00141	0		R/W	40121	0		Read
00142	1	AI Low Alarm Flag	R/W	40122	1	Historical Min. AI Value	Read
00143	Average Ch 0~1		R/W	40123	Average Ch 0~1		Read

40201	0	Type Code (The type codes of channels for average value can't be changed.)	Read
40202	1		Read
40203	Average Ch 0~1		Read

Modbus RTU

Address 0X	Ch	Description	Attribute	Address 4X	Ch	Description	Attribute
01001~01032	0~31	COM1 Bit value	R/W	41001~41032	0~31	COM1 Word value	R/W
				41101~41132	0~31	COM1 Bit value error code	Read
				41201~41232	0~31	COM1 Word value error code	Read

Miscellaneous

Address 0X	Ch	Description	Attribute	Address 4X	Ch	Description	Attribute
5001		RTC Battery Low Event	Read	45004		Battery Level (0 ~ 100%)	Read
5002		(Main) Battery Low Event	Read	45006		Power source (*4)	Read
				45011	(Upper word)	Timestamp	Read
				45012	(Lower word)		
				45301		RSSI (unit: - dBm)	Read
				45302		SNR (unit: dB)	Read
				45311~45314		*Device EUI (EUI-64)	Read
				45315~45316		Frame FCntUp	Read
				45317~45318		Frame FCntDown	Read
				45319		Packet Loss (0.01%)	Read

GPS

Address 0X	Ch	Description	Attribute	Address 4X	Ch	Description	Attribute
------------	----	-------------	-----------	------------	----	-------------	-----------

45401~45402	GPS - Latitude (degree *10 ⁵), N(+)/S(-)	Read
45403~45404	GPS - Longitude (degree *10 ⁵), E(+)/W(-)	Read

Table A.2: *AI Status: (1st Register at Low Address)

Bit Order	Description	I/O Type
0	Fail to provide AI value	AI, AO
1	Over Range	AI
2	Under Range	AI
3	Open Circuit (Burnout)	AI
4	Reserved	
5	Unavailable Channel Configuration	AI
6	Reserved	
7	ADC initializing/Error	AI
8	Reserved	
9	Zero/Span Calibration Error	AI, AO
10~15	Reserved	

Table A.3: *4 Power source

Bit Order	Description
0	Line power
1	Battery
2	Solar panel
3~15	Reserved

Table A.4: Modbus Type Code

0	0x0103	-150mv~150mv
1	0x0104	-500mv~500mv
2	0x0140	-1v~1v
3	0x0142	-5v~5v
4	0x0143	-10v~10v
5	0x0105	0~150mv
6	0x0106	0~500mv
7	0x0145	0~1v
8	0x0147	0~5v
9	0x0148	0~10v
10	0x0180	4mA~20mA
11	0x0181	-20mA~20mA
12	0x0182	0~20mA
13, 14		(Reserved)
15	0x03A9	PT100 (385) -200~ +600°C
16	0x03C9	PT100 (392) -200~ +600°C
17	0x03E2	PT1000 -40~ +160°C

Table A.5: WISE-4610-S615 (for WISE-6610 LoRaWAN GW)

RTD (AI)	4	DI	-	DO	-		
Address 0X	Ch	Description	Attribute	Address 4X	Ch	Description	Attribute
00101	0		Write	40001	0		Read
00102	1		Write	40002	1		Read
00103	2	Reset Historical Max. AI Value	Write	40003	2	AI Value	Read
00104	3		Write	40004	3		Read
00105	Average Ch 0~3		Write	40005	Average Ch 0~3		Read
00111	0		Write	40101~40102	0		Read
00112	1		Write	40103~40104	1		Read
00113	2	Reset Historical Min. AI Value	Write	40105~40106	2	*AI Status	Read
00114	3		Write	40107~40108	3		Read
00115	Average Ch 0~3		Write				
00131	0		R/W	40111	0		Read
00132	1		R/W	40112	1		Read
00133	2	AI High Alarm Flag	R/W	40113	2	Historical Max. AI Value	Read
00134	3		R/W	40114	3		Read
00135	Average Ch 0~3		R/W	40115	Average Ch 0~3		Read
00141	0		R/W	40121	0		Read
00142	1		R/W	40122	1		Read
00143	2	AI Low Alarm Flag	R/W	40123	2	Historical Min. AI Value	Read
00144	3		R/W	40124	3		Read
00145	Average Ch 0~3		R/W	40125	Average Ch 0~3		Read
				40201	0	Type Code (The type codes of channels for average value can't be changed.)	Read
				40202	1		Read
				40203	2		Read
				40204	3		Read
				40205	Average Ch 0~3		Read
Miscellaneous							
Address 0X	Ch	Description	Attribute	Address 4X	Ch	Description	Attribute
5001		RTC Battery Low Event	Read	45004		Battery Level (0 ~ 100%)	Read

5002	(Main) Battery Low Event	Read	45006	Power source (*4)	Read
			45011	(Upper word)	Timestamp
			45012	(Lower word)	
			45301	RSSI (unit: - dBm)	Read
			45302	SNR (unit: dB)	Read
			45311~45314	Device EUI	Read
			45315~45316	Frame FCntUp	Read
			45317~45318	Frame FCntDown	Read
			45319	Packet Loss (0.01%)	Read

GPS

Address 0X	Ch	Description	Attribute	Address 4X	Ch	Description	Attribute
				45401~45402		GPS - Latitude (degree *10 ⁵), N(+)/S(-)	Read
				45403~45404		GPS - Longitude (degree *10 ⁵), E(+)/W(-)	Read

Table A.6: *AI Status: (1st Register at Low Address)

Bit Order	Description	I/O Type
0	Fail to provide AI value	AI, AO
1	Over Range	AI
2	Under Range	AI
3	Open Circuit (Burnout)	AI
4	Reserved	
5	Unavailable Channel Configuration	AI
6	Reserved	
7	ADC initializing/Error	AI
8	Reserved	
9	Zero/Span Calibration Error	AI, AO
10~15	Reserved	

Table A.7: *4 Power source

Bit Order	Description
0	Line power
1	Battery
2	Solar panel
3~15	Reserved

Table A.8: Modbus Type Code

0	0x0103	-150mv~150mv
1	0x0104	-500mv~500mv
2	0x0140	-1v~1v
3	0x0142	-5v~5v
4	0x0143	-10v~10v
5	0x0105	0~150mv
6	0x0106	0~500mv
7	0x0145	0~1v
8	0x0147	0~5v
9	0x0148	0~10v
10	0x0180	4mA~20mA
11	0x0181	-20mA~20mA
12	0x0182	0~20mA
13, 14		(Reserved)
15	0x03A9	PT100(385) -200~ +600°C
16	0x03C9	PT100(392) -200~ +600°C
17	0x03E2	PT1000 -40~ +160°C

www.advantech.com

Please verify specifications before quoting. This guide is intended for reference purposes only.

All product specifications are subject to change without notice.

No part of this publication may be reproduced in any form or by any means, such as electronically, by photocopying, recording, or otherwise, without prior written permission of the publisher.

All brand and product names are trademarks or registered trademarks of their respective companies.

© Advantech Co., Ltd. 2024