

UNO-2484V3 電腦

**Intel Core Ultra (Arrow Lake)
5 & 7 Processor Modular Box PC
with 1 x GbE, 3 x 2.5 GbE,
1 x M.2 B-key, 2 x M.2 M-key,
1 x M.2 E-Key, 1 x HDMI, 1 x DP,
1 x USB2.0, 3 x USB 3.2,
2 x USB TypeC, and 4 x COM**

ADVANTECH

Enabling an Intelligent Planet

Copyright

The documentation and the software included with this product are copyrighted 2026 by Advantech Co., Ltd. All rights are reserved. Advantech Co., Ltd. reserves the right to make improvements in the products described in this manual at any time without notice. No part of this manual may be reproduced, copied, translated, or transmitted in any form or by any means without the prior written permission of Advantech Co., Ltd. The information provided in this manual is intended to be accurate and reliable. However, Advantech Co., Ltd. assumes no responsibility for its use, nor for any infringements of the rights of third parties that may result from its use.

Acknowledgments

Intel[®], Core[™] and Atom[™] are the trademarks of Intel Corporation.

Microsoft Windows and MS-DOS are registered trademarks of Microsoft Corp.

All other product names or trademarks are properties of their respective owners.

Support

For more information on this and other Advantech products, please visit our website at <http://www.advantech.com>

For technical support services, please visit our support website at <http://support.advantech.com/>

This manual applies to the following models:

UNO-2484V3-U25N1A	UNO-2484V3-U27N1A	UNO-2484V3-U25N1U	UNO-2484V3-U27N1U
UNO2484V3U252601-T	UNO2484V3U272601-T		
UNO2484V3U252602-T	UNO2484V3U272602-T		
UNO2484V3U252603-T	UNO2484V3U272603-T		
UNO2484V3U252604-T	UNO2484V3U272604-T		
UNO2484V3U252605-T	UNO2484V3U272605-T		
UNO2484V3U252606-T	UNO2484V3U272606-T		
UNO2484V3U252607-T	UNO2484V3U272607-T		
UNO2484V3U252608-T	UNO2484V3U272608-T		
UNO2484V3U252701-T	UNO2484V3U272701-T		
UNO2484V3U252702-T	UNO2484V3U272702-T		
UNO2484V3U252703-T	UNO2484V3U272703-T		
UNO2484V3U252704-T	UNO2484V3U272704-T		
UNO2484V3U252705-T	UNO2484V3U272705-T		
UNO2484V3U252706-T	UNO2484V3U272706-T		
UNO2484V3U252707-T	UNO2484V3U272707-T		
UNO2484V3U252708-T	UNO2484V3U272708-T		
UNO2484V3U252801-T	UNO2484V3U272801-T		
UNO2484V3U252802-T	UNO2484V3U272802-T		
UNO2484V3U252803-T	UNO2484V3U272803-T		
UNO2484V3U252804-T	UNO2484V3U272804-T		
UNO2484V3U252805-T	UNO2484V3U272805-T		
UNO2484V3U252806-T	UNO2484V3U272806-T		
UNO2484V3U252807-T	UNO2484V3U272807-T		

Part No. 2001248420

Edition 1

February 2026

UNO2484V3U252808-T	UNO2484V3U272808-T
UNO2484V3U252901-T	UNO2484V3U272901-T
UNO2484V3U252902-T	UNO2484V3U272902-T
UNO2484V3U252903-T	UNO2484V3U272903-T
UNO2484V3U252904-T	UNO2484V3U272904-T
UNO2484V3U252905-T	UNO2484V3U272905-T
UNO2484V3U252906-T	UNO2484V3U272906-T
UNO2484V3U252907-T	UNO2484V3U272907-T
UNO2484V3U252908-T	UNO2484V3U272908-T
UNO2484V3U253001-T	UNO2484V3U273001-T
UNO2484V3U253002-T	UNO2484V3U273002-T
UNO2484V3U253003-T	UNO2484V3U273003-T
UNO2484V3U253004-T	UNO2484V3U273004-T
UNO2484V3U253005-T	UNO2484V3U273005-T
UNO2484V3U253006-T	UNO2484V3U273006-T
UNO2484V3U253007-T	UNO2484V3U273007-T
UNO2484V3U253008-T	UNO2484V3U273008-T
UNO2484V3U253101-T	UNO2484V3U273101-T
UNO2484V3U253102-T	UNO2484V3U273102-T
UNO2484V3U253103-T	UNO2484V3U273103-T
UNO2484V3U253104-T	UNO2484V3U273104-T
UNO2484V3U253105-T	UNO2484V3U273105-T

Product Warranty (2 years)

Advantech warrants the original purchaser that each of its products will be free from defects in materials and workmanship for two years from the date of purchase.

This warranty does not apply to any products that have been repaired or altered by persons other than repair personnel authorized by Advantech, or products that have been subject to misuse, abuse, accident, or improper installation. Advantech assumes no liability under the terms of this warranty as a consequence of such events.

Because of Advantech's high quality-control standards and rigorous testing, most customers never need to use our repair service. If an Advantech product is defective, it will be repaired or replaced free of charge during the warranty period. For out-of-warranty repairs, customers will be billed according to the cost of replacement materials, service time, and freight. Please consult your dealer for more details.

If you believe your product to be defective, follow the steps outlined below.

1. Collect all the information about the problem encountered. (For example, CPU speed, Advantech products used, other hardware and software used, etc.) Note anything abnormal and list any onscreen messages displayed when the problem occurs.
2. Call your dealer and describe the problem. Please have your manual, product, and any helpful information readily available.
3. If your product is diagnosed as defective, obtain a return merchandise authorization (RMA) number from your dealer. This allows us to process your return more quickly.
4. Carefully pack the defective product, a completed Repair and Replacement Order Card, and a proof of purchase date (such as a photocopy of your sales receipt) into a shippable container. Products returned without a proof of purchase date are not eligible for warranty service.
5. Write the RMA number clearly on the outside of the package and ship the package prepaid to your dealer.

Declaration of Conformity

CE

This product has passed the CE test for environmental specifications when shielded cables are used for external wiring. We recommend the use of shielded cables. This type of cable is available from Advantech. Please contact your local supplier for ordering information.

Test conditions for passing also include the equipment being operated within an industrial enclosure. In order to protect the product from damage caused by electrostatic discharge (ESD) and EMI leakage, we strongly recommend the use of CE-compliant industrial enclosure products.

FCC Class A

This equipment has been tested and found to comply with the limits for a Class A digital device, pursuant to part 15 of the FCC Rules. These limits are designed to provide reasonable protection against harmful interference when the equipment is operated in a commercial environment. This equipment generates, uses, and can radiate radio frequency energy and, if not installed and used in accordance with the instruction manual, may cause harmful interference to radio communications. Operation of this equipment in a residential area is likely to cause harmful interference. In this event, users are required to correct the interference at their own expense.

警告使用者

為避免電磁干擾，本產品不應安裝或使用於住宅環境。

Technical Support and Assistance

1. Visit the Advantech website at www.advantech.com/support to obtain the latest product information.
2. Contact your distributor, sales representative, or Advantech's customer service center for technical support if you need additional assistance. Please have the following information ready before calling:
 - Product name and serial number
 - Description of your peripheral attachments
 - Description of your software (operating system, version, application software, etc.)
 - A complete description of the problem
 - The exact wording of any error messages

Safety Precautions - Static Electricity

Follow these simple precautions to protect yourself from harm and the products from damage.

- To avoid electrical shock, always disconnect the power from the PC chassis before manual handling. Do not touch any components on the CPU card or other cards while the PC is powered on.
- Disconnect the power before making any configuration changes. A sudden rush of power after connecting a jumper or installing a card may damage sensitive electronic components.

Safety Instructions

1. Read these safety instructions carefully.
2. Retain this user manual for future reference.
3. Disconnect the equipment from all power outlets before cleaning. Use only a damp cloth for cleaning. Do not use liquid or spray detergents.
4. For pluggable equipment, the power outlet socket must be located near the equipment and easily accessible.
5. Protect the equipment from humidity.
6. Place the equipment on a reliable surface during installation. Dropping or letting the equipment fall may cause damage.
7. The openings on the enclosure are for air convection. Protect the equipment from overheating. Do not cover the openings.
8. Ensure that the voltage of the power source is correct before connecting the equipment to a power outlet.
9. Position the power cord away from high-traffic areas. Do not place anything over the power cord.
10. All cautions and warnings on the equipment should be noted.
11. If the equipment is not used for a long time, disconnect it from the power source to avoid damage from transient overvoltage.
12. Never pour liquid into an opening. This may cause fire or electrical shock.
13. Never open the equipment. For safety reasons, the equipment should be opened only by qualified service personnel.
14. If any of the following occurs, have the equipment checked by service personnel:
 - The power cord or plug is damaged.
 - Liquid has penetrated the equipment.
 - The equipment has been exposed to moisture.
 - The equipment is malfunctioning, or does not operate according to the user manual.
 - The equipment has been dropped and damaged.
 - The equipment shows obvious signs of breakage.
15. Do not leave the equipment in an environment with a storage temperature of below -40°C (-40°F) or above 85°C (185°F) as this may damage the components. The equipment should be kept in a controlled environment.
16. **CAUTION:** Batteries are at risk of exploding if incorrectly replaced. Replace only with the same or equivalent type as recommended by the manufacturer. Discard used batteries according to the manufacturer's instructions.
17. In accordance with IEC 704-1:1982 specifications, the sound pressure level at the operator's position does not exceed 70 dB (A).
18. Ensure that the voltage of the power source is correct before connecting the equipment to a power outlet. The power outlet socket should have a grounded connection.
19. For use in pollution free environments and indoor use.
20. This equipment is not suitable for use in locations where children are likely to be present.
21. If the equipment is used in a manner not specified by the Advantech, the protection provided by the equipment may be impaired.
22. The equipment contains no user-serviceable parts. Do not open, Return to manufacturer for servicing.
23. Do not block air ventilation holes.

24. This is open type equipment and should be installed in a suitable enclosure.
25. Restricted Access Area: The equipment should only be installed in a Restricted Access Area.
26. This product is intended to be supplied by an UL certified power supply or dc source with SELV output, rated 10 Vdc, 7.7A minimum and Tma 40 degree. If you need further assistance, please contact Advantech for further information.
27. 26.This product is intended to be supplied by an UL Listed power supply suitable for use at Tma 60° C min. whose output meets ES1 (or SELV) is rated: (1) 10-36Vdc, 7.65A-2.12A min. (DC IN), if need further assistance, please contact Advantech for further information.



Caution: Hot surface. Do not touch for Top Heatsink.

DISCLAIMER: These instructions are provided according to IEC 704-1 standards. Advantech disclaims all responsibility for the accuracy of any statements contained herein.

Consignes de sécurité

1. Lire attentivement les instructions de sécurité.
2. Conserver ce manuel pour utilisation ultérieure,
3. Débranchez cet équipement de toute prise secteur avant le nettoyer. Utilisez seulement un chiffon humide. N'utilisez pas de détergent liquide ou pulvérisé pour le nettoyage.
4. Gardez cet équipement à l'abri de l'humidité.
5. Placez cet équipement sur une surface fiable pendant l'installation. Le faire ou bien le laisser tomber peut causer des dégâts.
6. Les ouvertures sur l'enceinte servent à la convection de l'air. Protégez l'équipement contre surchauffe. **NE COUVREZ PAS LES OUVERTURES.**
7. Assurez-vous que la tension de la source d'alimentation est correcte avant de connecter l'équipement à une prise de courant. La prise de courant doit avoir une connexion à la terre.
8. Placez le câble d'alimentation de manière à ce que personne ne puisse marcher dessus. Ne placez rien sur le câble d'alimentation.
9. Toutes les mises en garde et tous les avertissements sur l'équipement doivent être notés.
10. Si l'équipement n'est pas utilisé pendant une longue période, débranchez-le de la source d'alimentation pour éviter tout endommagement dû à une surtension transitoire.
11. Ne jamais verser de liquide dans une ouverture. Cela pourrait provoquer un incendie ou un choc électrique.
12. N'ouvrez jamais l'équipement. Pour des raisons de sécurité, l'équipement doit être ouvert uniquement par du personnel qualifié.
13. Si l'une des situations suivantes se présente, faites vérifier l'équipement par le personnel de service:
 - un liquide a pénétré dans l'équipement.
 - L'équipement a été exposé à l'humidité.
 - L'équipement ne fonctionne pas bien, ou vous ne pouvez pas le faire fonctionner selon le manuel de l'utilisateur.
 - L'équipement ne fonctionne pas bien, ou vous ne pouvez pas le faire fonctionner selon le manuel d'utilisation.

- L'équipement est tombé et endommagé.
 - L'équipement présente des signes évidents de rupture.
14. NE LAISSEZ PAS CET ÉQUIPEMENT DANS UN ENVIRONNEMENT OU LA TEMPÉRATURE DE STOCKAGE PEUT ÊTRE INFÉRIEURE À -40° C (-40° F) OU BIEN SUPÉRIEURE À 85° C (185° F). CECI POURRAIT ENDOMMAGER L'EQUIPEMENT. L'ÉQUIPEMENT DEVRAIT ÊTRE DANS UN ENVIRONNEMENT CONTRÔLÉ.
 15. Ce produit est destiné à être alimenté par une source d'alimentation certifiée UL ou par une source cc convenant à une utilisation à une température minimale de 40 degrés Celsius, dont la sortie est conforme à la norme SELV et dont la puissance nominale est de 10 Vdc, 7.7 A, en cas de besoin. contactez Advantech pour plus d'informations.
 16. Pour une utilisation dans des environnements non polluant et à l'intérieur.
 17. C'est appareil ne doit pas être utilisé dans des endroits où se trouvent des enfants.
 18. Si l'équipement est utilisé d'une manière non spécifiée par le fabricant, la protection fournie par l'équipement peut être altéré.
 19. L'équipement ne contient aucune pièce réparable par l'utilisateur. Ne pas ouvrir, retourner au fabricant pour réparation.
 20. Ne bloquez pas les ou es de ventilation.
 21. Il s'agit d'un équipement de type ouvert et doit être installé dans un boîtier approprié.



Attention: Surface chaude, ne pas toucher pour le dissipateur thermique supérieur.

22. **ATTENTION:** Danger d'explosion si la batterie est mal remplacée. Remplacer uniquement par le même type ou équivalent recommandé par le fabricant. Jeter les piles usagées selon les instructions du fabricant.

安全指示

1. 請仔細閱讀此安全操作說明。
2. 請妥善保存此用戶手冊供日後參考。
3. 用濕抹布清洗設備前，請確認拔除電源線。請勿使用液體或去污噴霧劑清洗設備。
4. 對於使用電源線的設備，設備周圍必須有容易接觸到的電源插座。
5. 請勿在潮濕環境中試用設備。
6. 請在安裝前確保設備放置在可靠的平面上，意外摔落可能會導致設備損壞。
7. 設備機殼的開孔適用於空氣對流，從而防止設備過熱。請勿覆蓋開孔。
8. 當您連接設備到電源插座前，請確認電源插座的電壓符合要求。
9. 請將電源線佈置在人們不易絆倒的位置，請勿在電源線上覆蓋任何雜物。
10. 請注意設備上所有的警告標示。
11. 如果長時間不使用設備，請拔除與電源插座的連結，避免設備被超標的電壓波動損壞。
12. 請勿讓任何液體流入通風口，以免引起火災或短路。
13. 請勿自行打開設備。為了確保您的安全，請透過經認證的工程師來打開設備。
14. 如遇下列情況，請由專業人員維修：
 - 電源線或插頭損壞；
 - 設備內部有液體流入；

- 設備曾暴露在過度潮濕環境中使用；
 - 設備無法正常工作，或您無法透過用戶手冊來正常工作；
 - 設備摔落或損壞；
 - 設備有明顯外觀損；
15. 請勿將設備儲存在超出建議溫度範圍的環境，即不要低於 -40°C (-40°F) 或高於 85°C (185°F)，否則可能會造成設備損壞。
 16. 注意：若電池更換不正確，將有爆炸危險。因此，只可以使用製造商推薦的同一種或者同等型號的電池進行替換。請按照製造商的指示處理舊電池。
 17. 根據 IEC 704 - 1:1982 規定，操作員所在位置音量不可高於 70 分貝。
 18. 限制區域：請勿將設備安裝於限制區域使用。
 19. 免責聲明：請安全訓示符合 IEC 704 - 1 要求。研華公司對其內容之準確性不承擔任何法律責任。
 20. 消費者若使用电源适配器供电，则应购买配套使用获得 CCC 认证并满足标准要求 的电源适配器。



警告：機殼高溫。請勿在使用過程中觸碰上方散熱鰭片。

Contents

Chapter 1	Overview	1
1.1	Introduction	2
1.2	Safety Precautions	2
1.3	Packing List.....	3
1.4	Hardware Specifications	3
1.4.1	General	3
	Table 1.1: General.....	3
1.4.2	System Hardware	3
	Table 1.2: System Hardware	3
1.4.3	I/O Interfaces	4
	Table 1.3: I/O Interfaces	4
1.4.4	Environment.....	4
	Table 1.4: I/O Interfaces	4
1.4.5	Certification.....	4
	Table 1.5: Certification.....	4
1.4.6	Extension Kit (Optional)	4
1.5	Dimensions	5
	Figure 1.1 UNO-2484V3 Dimensions	5
	Figure 1.2 UNO-2484V3 Dimensions (with optional extension kit)	5
	5	
Chapter 2	Hardware Functionality	7
2.1	Introduction	8
	Figure 2.1 Front Panel of UNO-2484V3	8
	Figure 2.2 Rear Panel of UNO-2484V3	8
2.2	Serial Communication Ports.....	9
2.2.1	COM Port Interfaces (COM1, COM2, COM3, COM4)	9
2.2.2	Power Connector	9
2.2.3	LAN: Ethernet Connector.....	9
2.2.4	USB Connector	9
2.2.5	HDMI Connector	9
2.2.6	DP Connector	9
2.2.7	RTC Battery	9
2.2.8	Power Button/Power Management	9
2.2.9	Reset Button	10
2.2.10	M.2 B-key Connector	10
2.2.11	M.2 M-key Connector.....	10
2.2.12	Nano SIM Slot.....	10
2.2.13	LED Indicators	10
2.3	Base Unit's Internal Connectors.....	11
	Figure 2.3 UNO-2484V3 Connector Locations (Top Side)	11
	Figure 2.4 UNO-2484V3 Key Component Locations (Bottom Side)	11
	11	
	Table 2.1: Connectors and Jumpers	12
2.4	Clear CMOS Function (CMOS1).....	12
	Table 2.2: CMOS Clear Data.....	12
Chapter 3	Initial Setup	13
3.1	Chassis Grounding.....	14
	Figure 3.1 Chassis Grounding Connection	14
3.2	Connect the Power Supply.....	15

	Table 3.1: Power Connector Pin Assignments.....	15
3.3	Install SMT Cable.....	16
3.4	Install SIM Card	17
3.5	Remove and Recover BTM Cover (for Level 2 (LV2) Installation).....	18
3.6	Installing LV2 Expansions.....	20
3.7	Install LV2 Expansion (Replace Thermal Chunk)	23
3.8	Install LV2 Expansion (for SATA)	25
3.9	Install LV2 Expansion (for 2-iDOOR SKU).....	26

Chapter 4 BIOS Operations 27

4.1	Introduction	28
	Figure 4.1 Main Setup Screen.....	28
4.2	Entering BIOS Setup.....	28
4.2.1	Main Menu.....	29
4.2.2	Advanced BIOS Features.....	29
	Figure 4.2 Advanced BIOS Features Setup Screen.....	29
	Figure 4.3 CPU Configuration - 1	30
	Figure 4.4 Power & Performance-1	31
	Figure 4.5 CPU - Power Management Control-1.....	31
	Figure 4.6 View/configure Turbo Option -1.....	32
	Figure 4.7 View/Configure Turbo Option -2.....	33
	Figure 4.8 Config TDP Configurations.....	33
	Figure 4.9 GT – Power Management Control.....	35
	Figure 4.10ME State.....	35
	Figure 4.11TPM Device Configuration -1	36
	Figure 4.12TPM Device Configuration - 2	36
	Figure 4.13Trusted Computing-2.....	37
	Figure 4.14ACPI Setting -1.....	38
	Figure 4.15NCT61260 Super IO Configuration	39
	Figure 4.16NCT61260 Super IO Configuration	39
	Figure 4.17H/W Monitor Configuration-1	41
	Figure 4.18S5 RTC Make Settings -1.....	41
	Figure 4.19S5 RTC Make Settings -2.....	42
	Figure 4.20USB Configuration -1	43
	Figure 4.21USB Configuration-2	43
	Figure 4.22Network Stack Configuration - 1.....	44
	Figure 4.23NVMe Configuration -1.....	45
	Figure 4.24NVMe Configuration-2.....	46
4.3	Chipset.....	47
	Figure 4.25System Agent (SA) Configuration - 1	47
	Figure 4.26Memory Configuration	47
	Figure 4.27VMD Setup Menu	48
	Figure 4.28SATA Configuration - 1	49
	Figure 4.29SATA Configuration -	49
	Figure 4.30PCH-IO Configuration – 2	50
	Figure 4.31USB Configuration.....	51
4.4	Security.....	52
	Figure 4.32Security	52
	Figure 4.33Secure Boot - 1	52
	Figure 4.34Secure Boot.....	53
4.5	Boot.....	54
	Figure 4.35Boot	54
4.6	Save & Exit	55
	Figure 4.36Save & Exit.....	55

Appendix A System Settings/Pin Assignments.. 57

A.1	Power Connector (DCIN1).....	58
-----	------------------------------	----

	Table A.1: Power Connector Pin Assignments	58
A.2	Clear CMOS Function (CMOS1).....	58
	Table A.2: Clear CMOS Function (CMOS1)	58
A.3	USB Connector	59
A.3.1	USB 2.0 Connector (USB2A1).....	59
	Table A.3: USB Pin Assignments	59
A.3.2	USB 3.2 Connector (USB3A1/USB3A2/USB3A3)	59
	Table A.4: USB Pin Assignments	59
A.4	HDMI Connector (HDMI1).....	60
	Table A.5: HDMI Port Adapter Cable Pin Assignments	60
A.5	COM Port RS232/422/485 Settings	61
	Table A.6: COM Port RS232/422/485 Settings.....	61
A.6	LAN1/2/3/4 RJ45 Connector	62
	Table A.7: LAN1/2/3/4 RJ45 Connector.....	62
	Table A.8: LED (I226)	62
	Table A.9: LED (I219)	62
A.7	GPIO Port (GPIO1)	63
	Table A.10:GPIO Port (GPIO1).....	63
A.8	DP Connector (DP1)	64
	Table A.11:Display Port Adapter Cable Pin Assignments	64
A.9	Type-C Connector (TYPEC1)	65
	Table A.12:mPCIe Connector Pin Assignments	65
A.10	AT/ATX Setting (PSON1).....	66
	Table A.13:AT/ATX Setting (PSON1)	66
A.11	DC in Setting (DCOUT1).....	66
A.12	Slide Switch Setting (SW1)	67
A.13	Remote Power Setting (FP1)	67
A.14	RAID0/RAID1 Setting.....	67

Chapter 1

Overview

This chapter provides an overview of UNO-2484V3 specifications.

- Introduction
- Safety Precautions
- Accessories

1.1 Introduction

The UNO-2484V3 is a ready-to-use embedded hardware platform that is designed to streamline development time. Featuring a robust set of networking interfaces that cater to diverse application needs, the system is powered by Intel® Core™ Ultra 5 and 7 (Arrow Lake) processors and comes with optional DDR5 memory. Operating seamlessly within a wide temperature range of -20 ~ 60°C (-4 ~ 140°F), it boasts extensive I/O capabilities, including 1× GbE, 3× 2.5 GbE, 1× M.2 B Key, 2× M.2 M Key, 1× HDMI, 1× DP, 1× USB 2.0, 3× USB 3.2, 1× USB Type-C, and 4× COM ports.

Furthermore, the system supports expansion with an optional second-stack extension kit that accommodates either 2× iDoor modules, such as industrial Fieldbus modules, or additional I/O and peripheral modules, or 2× HDDs.

For convenient expansion, the UNO-2484V3 includes one M.2 B Key, two M.2 M Keys, and one M.2 E Key. This allows seamless integration of high-speed technologies such as Wi-Fi 6, 5G, and NVMe SSDs, enhancing data transmission efficiency. With compatibility with multiple drivers and operating systems, including Windows 11 and Linux, users can effortlessly integrate applications into this application-ready platform, meeting diverse requirements.

1.2 Safety Precautions

Below are a few safety precautions for preventing injury when making connections. In most cases, you can use a standard cable for connection.

Warning! *Always disconnect the power cord from the chassis before manual handling. Do not make any configuration changes when the power is on.*



The sudden rush of power can damage sensitive electronic components. Only experienced electronics personnel should open the chassis.

Warning! *Toujours à la terre pour éliminer toute charge d'électricité statique avant de toucher UNO-2484V3. Appareils électroniques modernes sont très sensibles à charges d'électricité statique. Utilisez un bracelet antistatique à tout moment. Placez tous composants électroniques sur une surface antistatique ou dans un sac blindé.*



Toujours à la terre pour éliminer toute charge d'électricité statique avant de toucher UNO-2484V3. Appareils électroniques modernes sont très sensibles à charges d'électricité statique. Utilisez un bracelet antistatique à tout moment. Placez tous composants électroniques sur une surface antistatique ou dans un sac blindé.

Caution! *Always ground yourself to remove any static electric charge before touching UNO-2484V3. Modern electronic devices are very sensitive to static electric charges. Use a grounding wrist strap at all times. Place all electronic components on a static-dissipative surface or in a static-shielded bag.*



Always ground yourself to remove any static electric charge before touching UNO-2484V3. Modern electronic devices are very sensitive to static electric charges. Use a grounding wrist strap at all times. Place all electronic components on a static-dissipative surface or in a static-shielded bag.

Caution! *Toujours débrancher le cordon d'alimentation de votre boîtier lorsque vous êtes travailler. Ne branchez pas lorsque l'appareil est allumé. Un afflux soudain de puissance peut endommager les composants électroniques sensibles. Seulement connu personnel de l'électronique devraient ouvrir le châssis.*



Toujours débrancher le cordon d'alimentation de votre boîtier lorsque vous êtes travailler. Ne branchez pas lorsque l'appareil est allumé. Un afflux soudain de puissance peut endommager les composants électroniques sensibles. Seulement connu personnel de l'électronique devraient ouvrir le châssis.

1.3 Packing List

Please refer to below packing list:

- UNO-2484V3
- 1 x plug-in block for power wiring
- Startup manual
- Thermal pad for M.2 M key module (1pcs*1990042505N000) & RAM (1pcs *1990042331N000)

If anything is missing or damaged, contact your distributor or sales representative immediately.

1.4 Hardware Specifications

1.4.1 General

Table 1.1: General	
Dimensions (W x D x H)	200 x 140 x 55mm (7.07 x 5.6 x 2.1 in)
Weight (Net)	3kg (6.61lbs)
Mounting	Stand/Wall mount (1930001361*3pcs)
Power Requirement	10 - 36VDC
Power Consumption	31W (typical), 97W (Max), 109W (with 2nd stack)

1.4.2 System Hardware

Table 1.2: System Hardware	
BIOS	AMI EFI X64
Watchdog Timer	Programmable 255 levels timer interval, from 1 to 255 sec
Hardware Security	TPM 2.0
Processor	Ultra 7 255U 12 Cores 5.2GHz or Ultra 5 225U 12 Cores 4.8GHz
Memory	Optional DDR5 5600MHz, per channel supports up to 32GB
Graphics Engine	Intel® Iris® Xe Graphics
Ethernet	Intel® Ethernet Controller i219/i226-LM *2, IEEE1588/802.1AS 803.3az
LED Indicators	1 x power, 1 x NVMe, 1 x battery
Expansion	<ul style="list-style-type: none"> ■ 1 x M.2 B key slot (USB signal for 3042/3052 LTE/5G Module) ■ 2 x M.2 M key (PCIe x4) ■ *2nd stack: 2 x 2.5" SSD (via UNO-2484V3-ES2A)

1.4.3 I/O Interfaces

Table 1.3: I/O Interfaces

LAN Ports	3 x RJ45, 10/100/1000/2500 Mbps 1 x RJ45, 10/100/1000 Mbps IEEE 802.3u 1000BASE-T Fast Ethernet
USB Ports	3 x USB 3.2 Gen2, 1 x USB 2.0, 2 x USB 3.2 Type-C (1.5A), supports DP 1.4a & DP ALT mode
Displays	1 x HDMI 1.4 (1920 x 1080@60Hz), 1 x DP 1.4 (3840 X 2160@60Hz)
Power Connector	1 x 2 pin terminal block

1.4.4 Environment

Table 1.4: I/O Interfaces

Operating Temperature*	-20 ~ 60°C (-4 ~ 140°F) with 0.7 m/s airflow
Storage Temperature	-40 ~ 85°C (-40 ~ 185°F)
Relative Humidity	■ Operating, 95% RH @ 40°C, non-condensing ■ Non-Operating, 95% RH @ 60°C, condensing
Shock Protection	Operating, IEC 60068-2-27, 50G, half sine, 11ms
Vibration Protection	Operating, IEC 60068-2-64, 2Grms, random, 5 ~500Hz, 1hr/axis (SSD)
Ingress Protection	IP20

1.4.5 Certification

Table 1.5: Certification

Certification	CE, FCC, UL, CCC, BSMI
----------------------	------------------------

1.4.6 Extension Kit (Optional)

UNO-2484V3 features a modularized design. Advantech offers 3 optional 2nd stack extension kits for users to expand functionality.

1.5 Dimensions

200 x 140 x 55 mm (7.8" x 5.6" x 2.1")

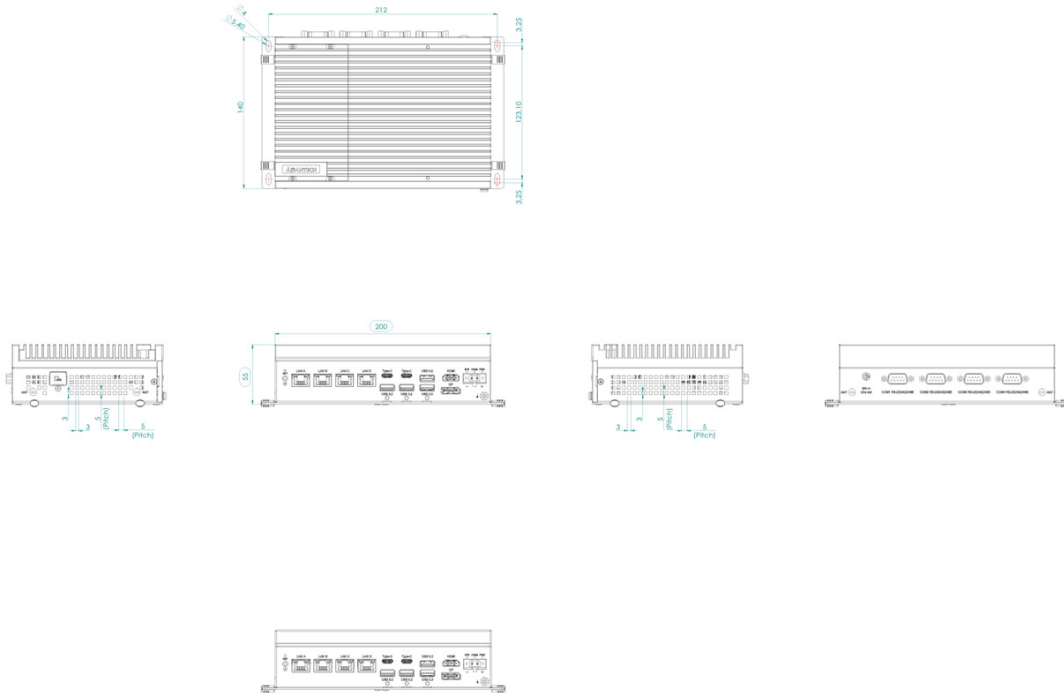

Figure 1.1 UNO-2484V3 Dimensions

200 x 140 x 90 mm (7.8" x 5.6" x 3.54")

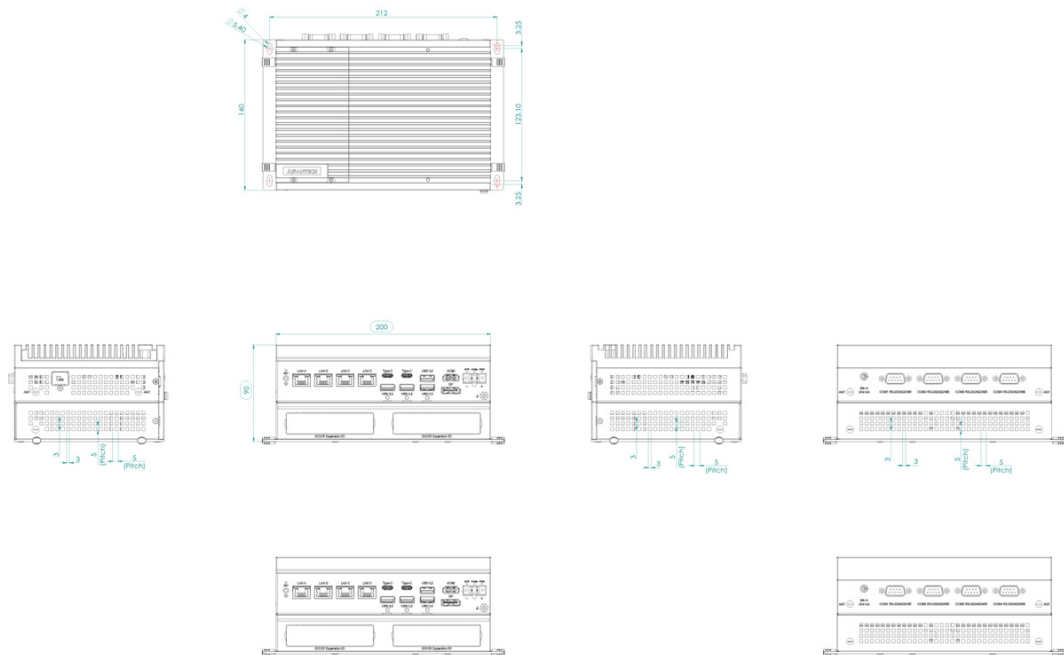

Figure 1.2 UNO-2484V3 Dimensions (with optional extension kit)

Chapter 2

Hardware Functionality

This chapter explains how to setup the UNO-2484V3's hardware functions, including connecting peripherals and setting switches and indicators.

- Introduction
- UNO-2484V3 Interface
- LAN/Ethernet Connector
- Power Connector
- USB Connector
- RTC Battery
- Power Button/Power Management
- Reset Button
- PCI Express Mini Card Socket

2.1 Introduction

The diagram below illustrates the placement of the UNO-2484V3's motherboard and extension kit's internal and external connectors.

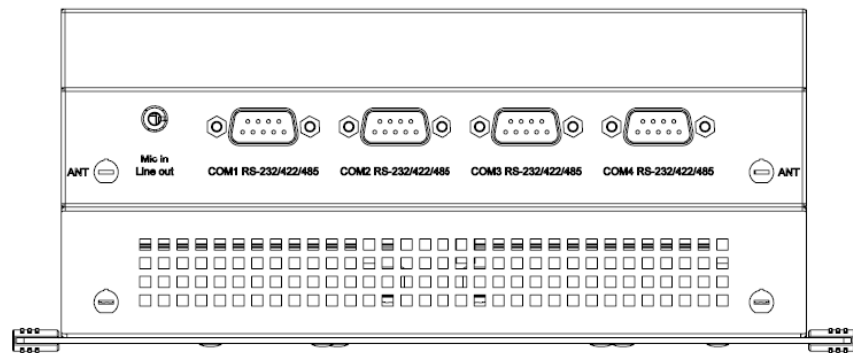
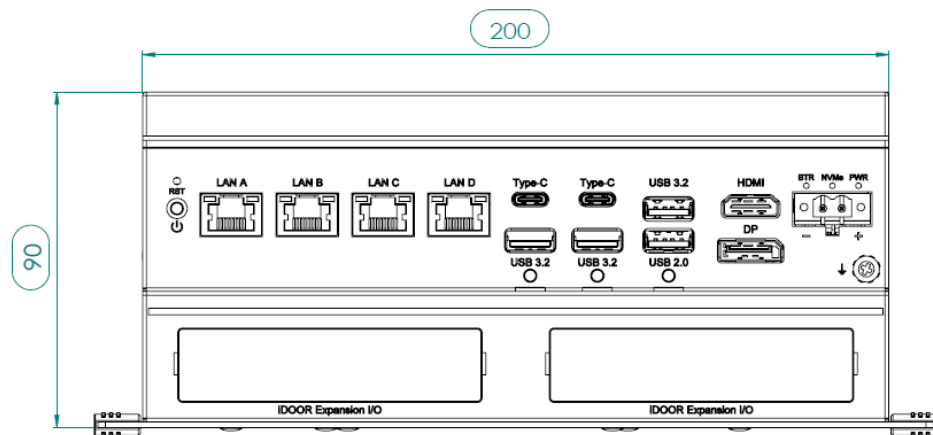

Figure 2.1 Front Panel of UNO-2484V3

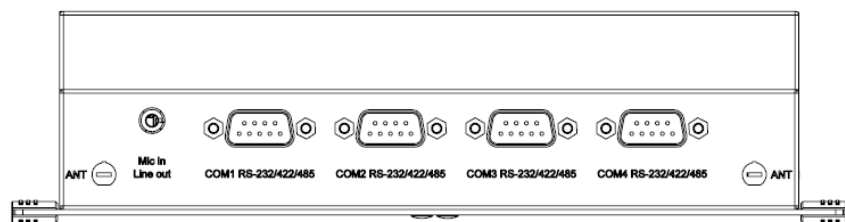

Figure 2.2 Rear Panel of UNO-2484V3

2.2 Serial Communication Ports

Key features of the UNO-2484V3 include four standard COM serial communication ports (COM1, COM2, COM3, and COM4), which can be configured in the BIOS menu, with drivers automatically installed during OS installation.

2.2.1 COM Port Interfaces (COM1, COM2, COM3, COM4)

The system also boasts four RS-232/422/485 ports (DB9, 50 ~ 115.2 kbps), defaulting to RS-232 for COM1 ~ 4, with adjustable settings in the BIOS menu (refer to User Manual - Appendix A.5 for RS232/422/485 settings).

2.2.2 Power Connector

A Phoenix connector facilitates 10 - 36 VDC external power input with reversed wiring protection (pin assignments in User Manual - Appendix A.1).

2.2.3 LAN: Ethernet Connector

Equipped with two Gigabit LAN controllers, the UNO-2484V3 utilizes an Intel® i219-LM/Ethernet controller for 10/100/1000 Mbps and three Intel® i226-LM/Ethernet controllers for 10/100/1000/2500 Mbps. The Ethernet port is a standard RJ-45 jack with LED indicators on the front displaying Link (off/green/orange) and Active (green) status (pin assignments in User Manual - Appendix A.6).

2.2.4 USB Connector

UNO-2484V3 features 3 x USB ports for Rev. 3.2 specifications and 1 x USB 2.0 port. The USB connectors support plug-and-play and hot-swap-ping functionality for external devices. Additionally, this can be enabled/disabled in the BIOS menu. (Please refer to User Manual- Appendix A.3 for pin assignments.)

2.2.5 HDMI Connector

The UNO-2484V3 provides 1 x HDMI 1.4 connector for a high resolution interface, 1920 X 1080 @60Hz. (Please refer to User Manual- Appendix A.4 for pin assignments.)

2.2.6 DP Connector

The UNO-2372G V2 provides 1 x DP 1.4a connector for a high resolution interface, 3840 x 2160 @ 60Hz. (Please refer to User Manual- Appendix A.8 for pin assignments.)

2.2.7 RTC Battery

The UNO-2484V3 is equipped with an RTC battery to ensure that the system clock and BIOS settings are retained after power disconnections.

- **Type:** CR2032
- **Output Voltage:** 3 V_{DC}

2.2.8 Power Button/Power Management

The "PWR" button controls the power on/off (ATX type), configurable to AT mode for automatic system startup with power input (refer to Appendix A.1 for details).

2.2.9 Reset Button

Press the “Reset” button to activate the hardware reset function.

2.2.10 M.2 B-key Connector

There is one M.2 B Key connector for M.2 cards, labeled “M2_B1” on the mother board. This M.2 interface is USB3.0 signal. It supports the installation of M.2 3042/3052 module (w/ USB 3.0 Signal).

Note! *In addition to the M.2 B key (M2_B1) socket, the system features a micro SIM slot for supporting the 5G/LTE function. However, users are required to install a 5G/LTE M.2 B key module to enable this function.*



2.2.11 M.2 M-key Connector

There is one M.2 M Key connector for M.2 cards, labeled “NVME1” on the mother board. This M.2 M key interface is a PCIe x4 signal. it supports the installation of a M.2 2280 storage module.

2.2.12 Nano SIM Slot

There is one Nano SIM slot for LTE function support. In addition to installing a SIM card on “SIM1”, users are required to install a LTE Module on the “M2_B1” M.2 B Key to enable this functionality.

2.2.13 LED Indicators

Three LEDs indicate the status of the system’s power and RTC battery.

■ **PWR (Power):** Green indicates “normal” and orange indicates “standby”.

Two antenna mounting holes facilitate the installation of an antenna kit for LTE or wireless functions.

2.3 Base Unit's Internal Connectors

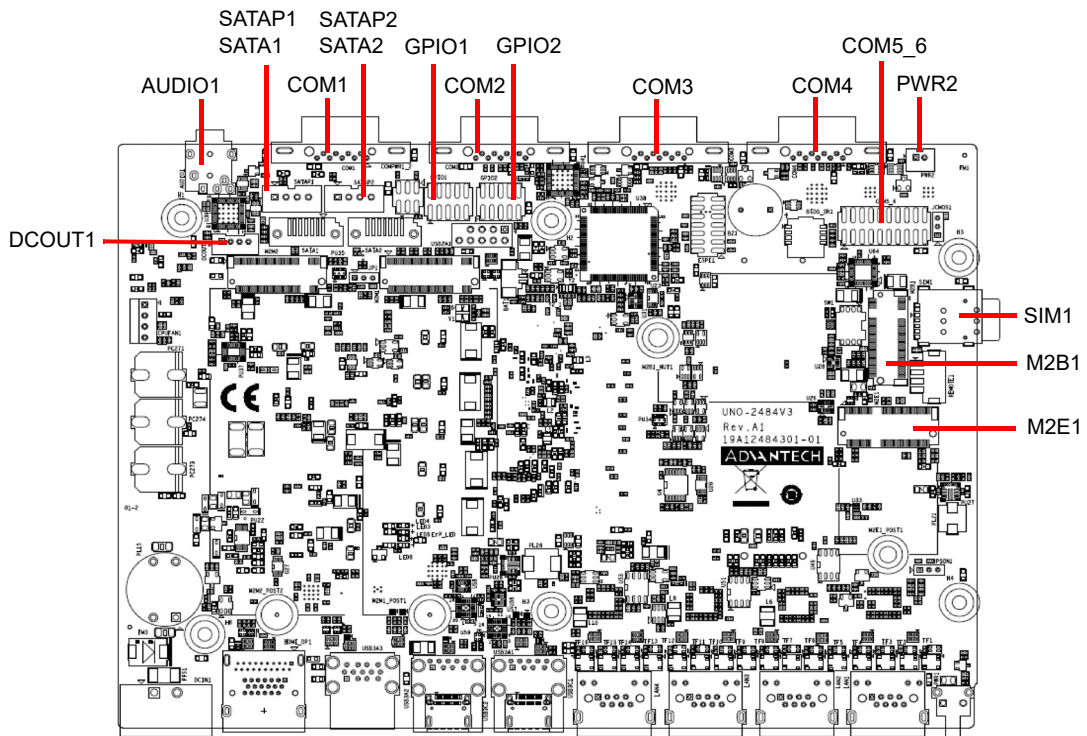

Figure 2.3 UNO-2484V3 Connector Locations (Top Side)

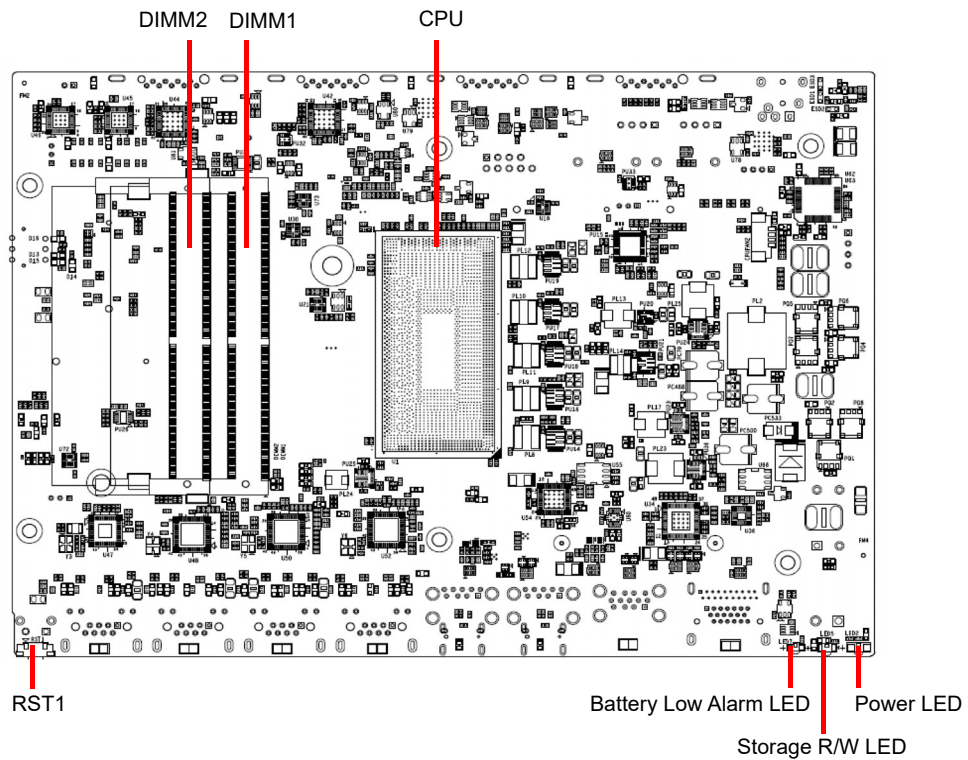
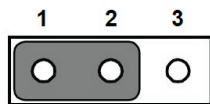

Figure 2.4 UNO-2484V3 Key Component Locations (Bottom Side)

Table 2.1: Connectors and Jumpers

Location Name	Description
DCIN1	DC Input Connector (Adapter)
DCOUT1	DC output Connector
COM1/COM2/ COM3/ COM4	COM Port Connector (RS232+RS422+RS485)
COM5/ COM6	COM Port Connector (RS232 only)
AUDIO1	Audio Connector
GPIO1/ GPIO2	GPIO Connector
M2M1	M.2 Socket - M-Key 2280 (PCIeX4)
M2M2	M.2 Socket - M-Key 2280 (PCIeX4)
M2B1	M.2 Socket - B-Key 3042/ 3052 (USB3.1/ USB2.0/ PCIe)
M2E1	M.2 Socket - E-Key 2230 (USB2.0/ PCIe)
BAT1	RTC Battery Connector
SIM1	Nano SIM Connector
USB2A1	CONN USB2.0*2
LAN1	RJ45 I219LM(10/100/1000 Mbps)
LAN2/ LAN3/LAN4	RJ45 I226LM(10/100/1000/2500 Mbps)
USB3C1/ USB3C2	Type C
USB3A1/ USB3A2	USB3.2 (Gen2) Type A
USB3A3	USB3.1*1 (Gen1) Type A
USB2A1	USB2.0 Type A
HDMI1	HDMI
DP1	DP

2.4 Clear CMOS Function (CMOS1)



*Keep CMOS data

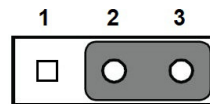

Clear CMOS data

Table 2.2: CMOS Clear Data

Closed Pins	Result
1-2	*Keep CMOS data
2-3	Clear CMOS data
*Default	

Chapter 3

Initial Setup

This chapter explains the process for initializing the UNO-2484V3.

- Chassis Grounding
- Connect the Power Supply
- Open/Close the Rear Cover
- Hard Disk Installation
- Extension Kit LV2 Installation

3.1 Chassis Grounding

The UNO-2484V3 provides adequate EMI protection and a stable grounding base. Moreover, an easy-to-connect chassis grounding point is also provided.



Figure 3.1 Chassis Grounding Connection



Cabinet/Rack System Installation:

1. Connect the cabinet/Rack system to the earth/ground.
2. Install the UNO device into the cabinet/Rack system without I/O or power cables.

System Wiring:

1. Connect the cabinet/rack system to the earth/ground.
2. Ensure that all cabinets/rack systems have been grounded together.
3. Connect the ground of the power supply to the cabinet/rack system.
4. Connect the ground pin of UNO device to the cabinet/rack system.

3.2 Connect the Power Supply

The UNO-2484V3 is intended to be supplied by an approved power adapter or DC power source. This adapter is rated at 10 - 36dc, and has a Tmax of 60°C (140°F). If you need further assistance or information, please contact Advantech.

Note! *It is recommended to choose a 150W adapter when the iDoor expansion module (e.g. PCM-24R2PE) is installed. Recommended PN: 96PSA-A150W24T2-4.*



Follow these instructions:

1. Insert the positive and negative wires into the V+ and V- contacts on the terminal block connector.
2. Tighten the wire-clamp screws to prevent the DC wires from coming loose.

Take the following guidelines into consideration before wiring the device:

1. The terminal block is suitable for 14-24 AWG (8A). The torque value is 7.0 lb-in, pitch 5.08mm. Use copper conductors only.
2. The temperature rating of the input connection cable should be higher than 105°C (221°F).

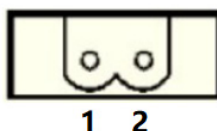
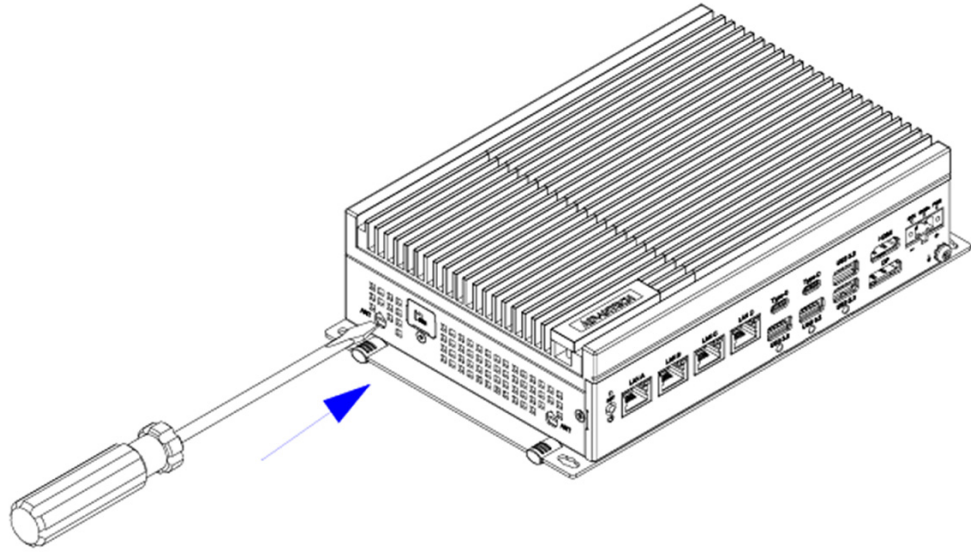

Table 3.1: Power Connector Pin Assignments

Pin	Signal	Description
1	Power IN V+	10 -36 V _{DC}
2	Power IN V- (GND)	

3.3 Install SMT Cable

1. Knock out the ANT hole.



2. Install the SMT cable.

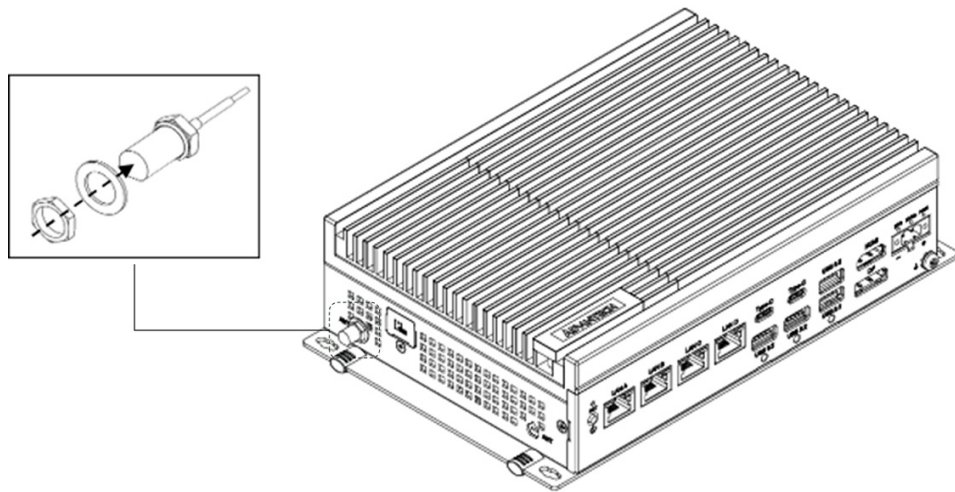

3.4 Install SIM Card

1. Unscrew (1930008390*1) and remove the SIM cover (1960118543N001).

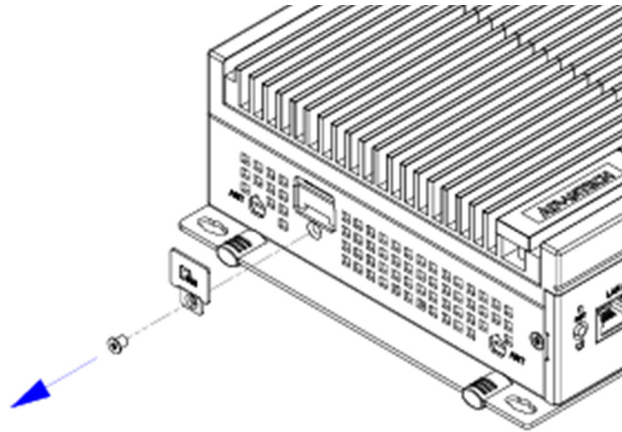

2. Insert the SIM card.

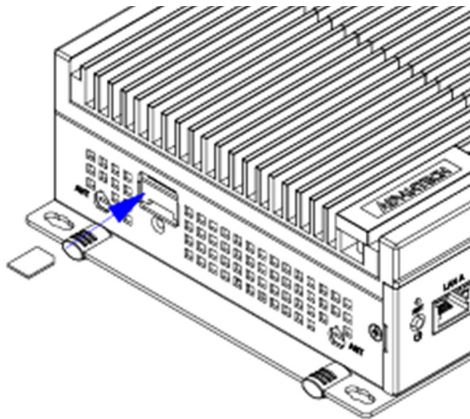

3. Re-attach the SIM cover (1960118543N001) and lock with screws(1930008390*1).

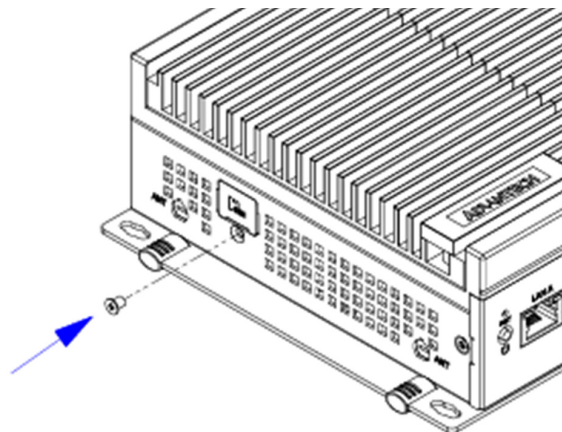

3.5 Remove and Recover BTM Cover (for Level 2 (LV2) Installation)

1. Undo screws (1930008390*6) and stoppers (1990038767S001*2) and remove BTM cover (1960105540T011).

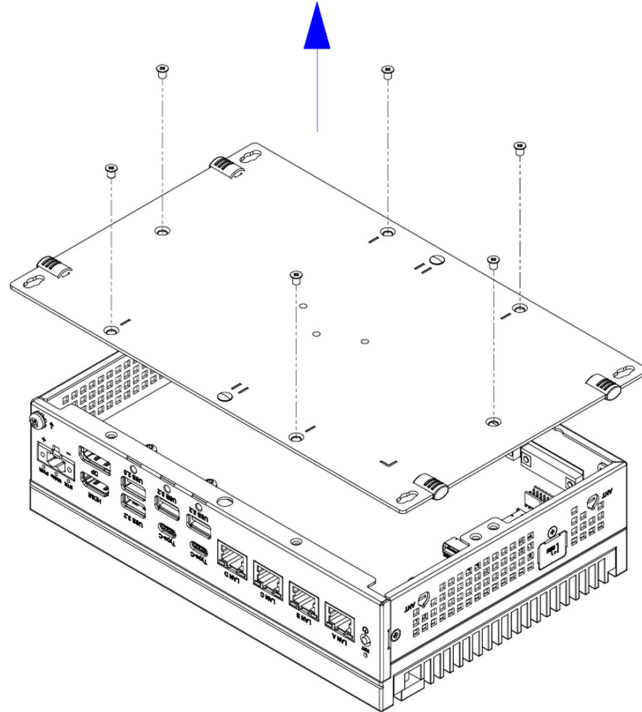

2. Re-attach the BTM cover (1960105540T011), and fix with screws (1930008390*4) and stoppers (1990038767S001*4).

LV2 Expansion (for 2-SATA SKU)

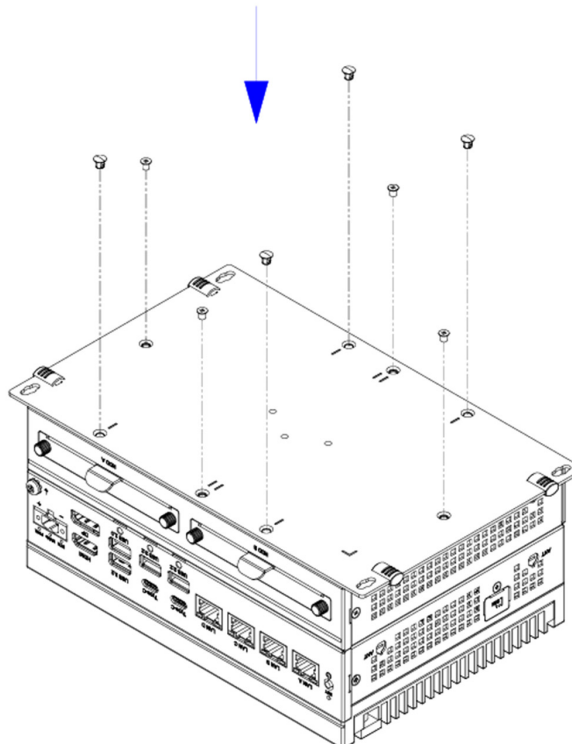

LV2 Expansion (for 2-iDOOR SKU)

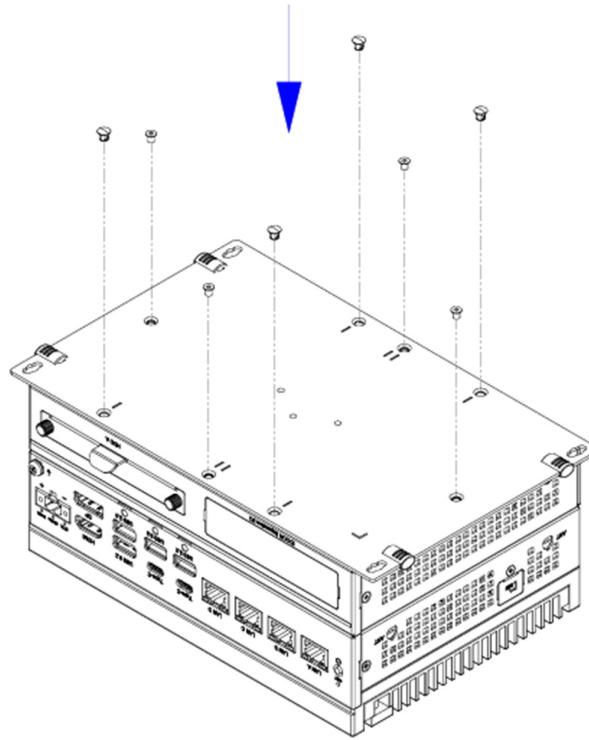

LV2 Expansion (for SATA+iDOOR SKU)

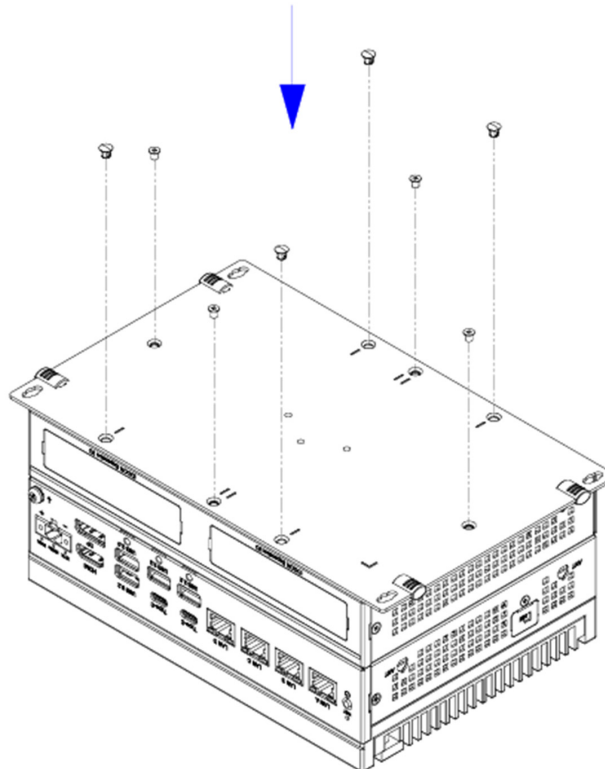

3.6 Installing LV2 Expansions

1. Installing LV2 for SATA*2 and iDoor expansions, with screws (1930008390*4)

LV2 Expansion (for 2-SATA SKU)

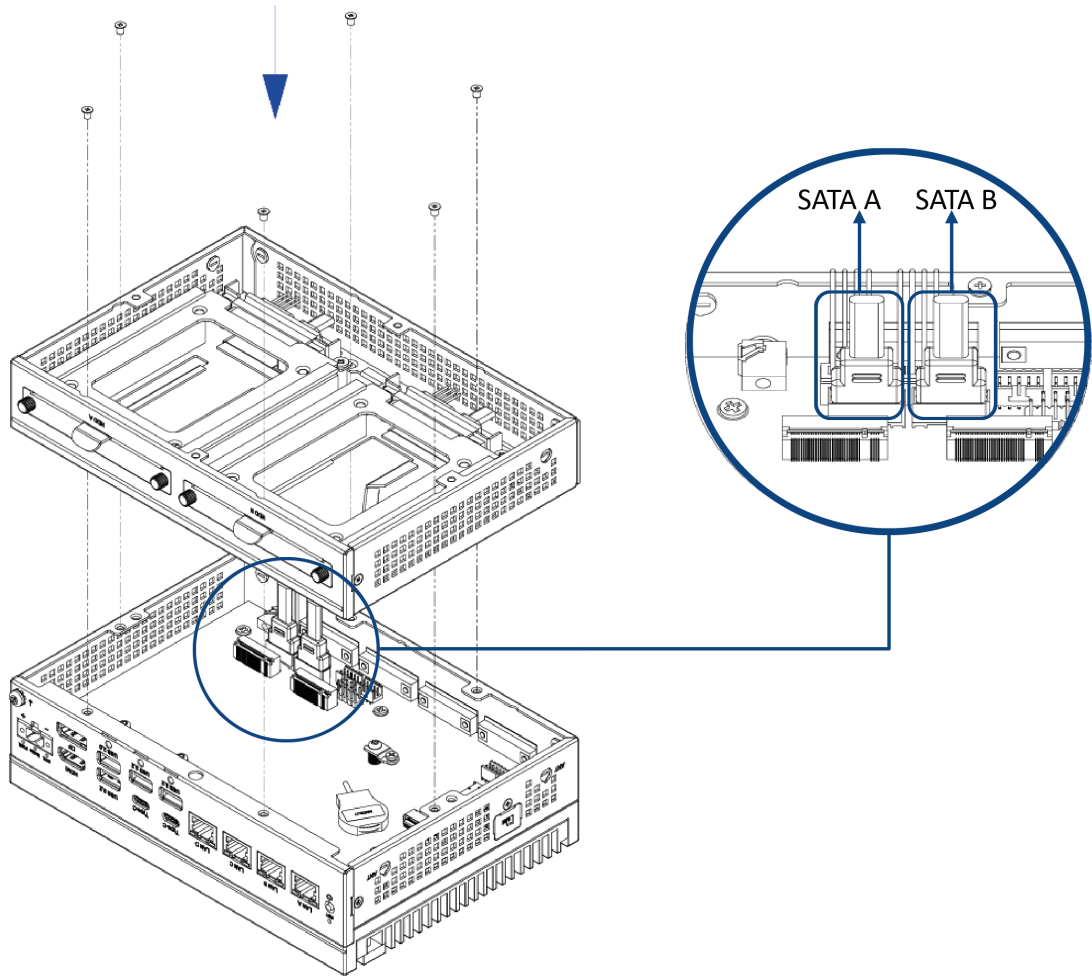

LV2 Expansion (for 2-iDOOR SKU)

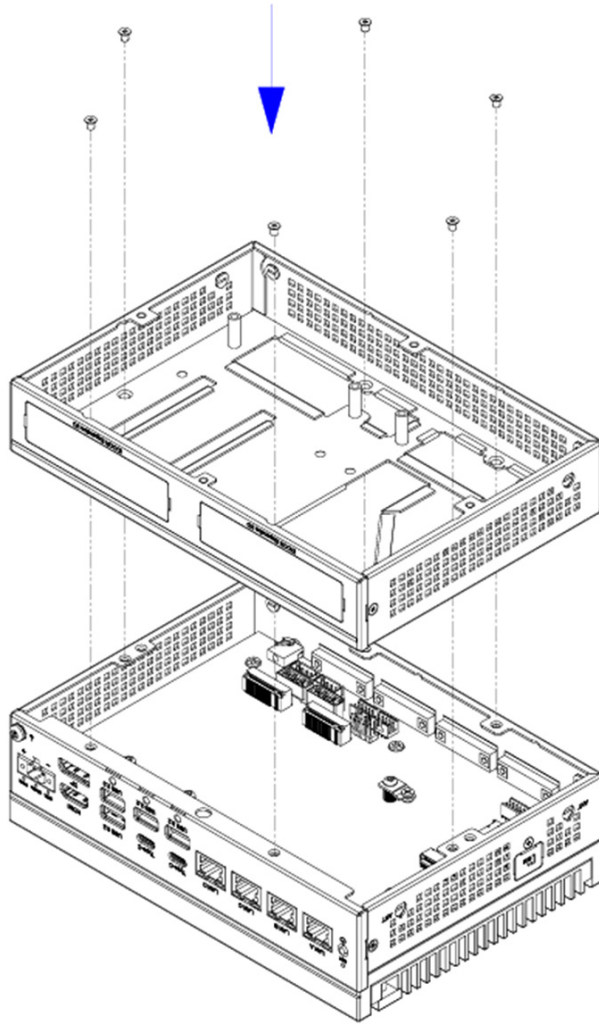

LV2 Expansion (for SATA+iDOOR SKU)

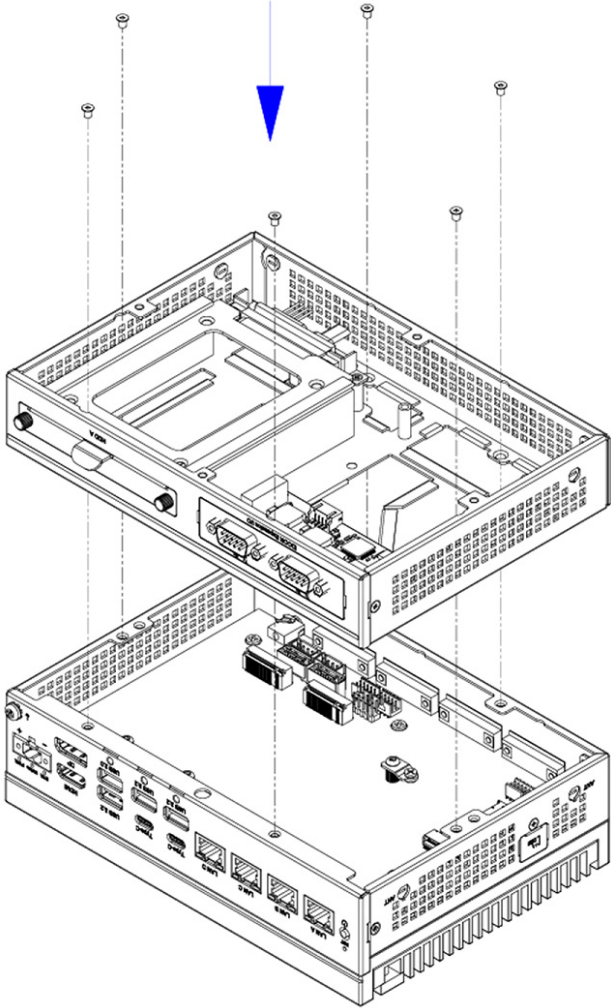

3.7 Install LV2 Expansion (Replace Thermal Chunk)

1. Undo screws (1930007680-01*6) and remove the thermal chunks.

For:

M-Key chunk (1960119414N000)

B-Key chunk (1960119412N000)

E-Key chunk (1960119413N000)

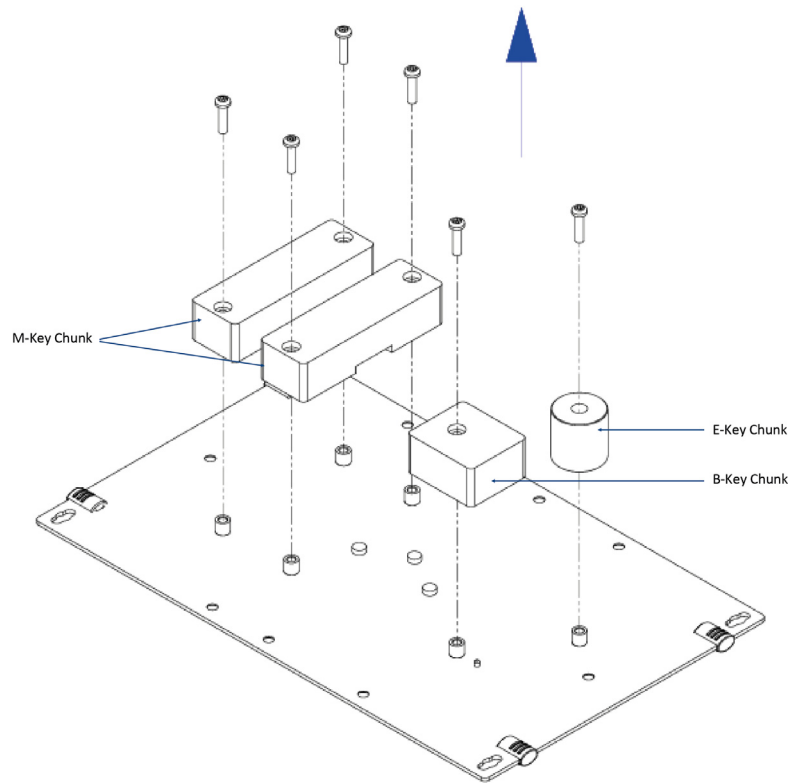

2. Install thermal chunks, and fix with screws (1930007680-01*6).

For:

M-Key chunk (1960119414N000)

B-Key Chunk (1960119412N000)

E-Key Chunk (1960119413N000)

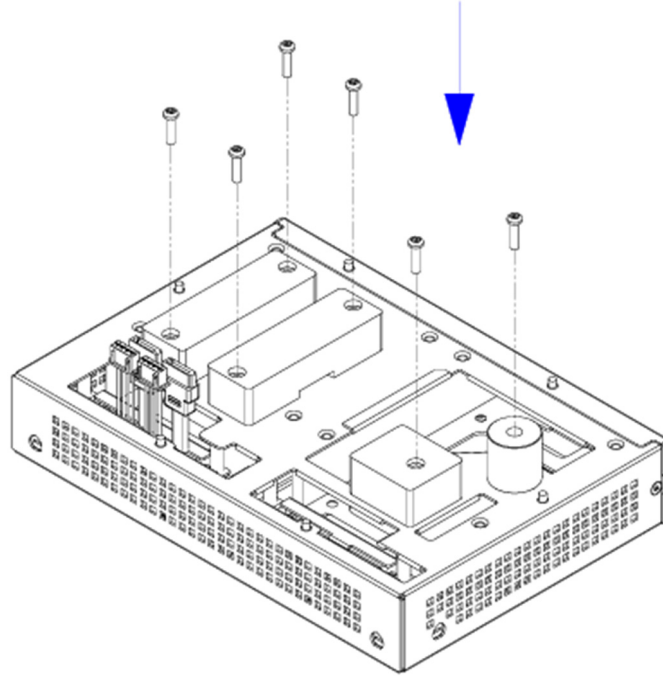

3.8 Install LV2 Expansion (for SATA)

1. Release the SATA bracket (1960100982N011).

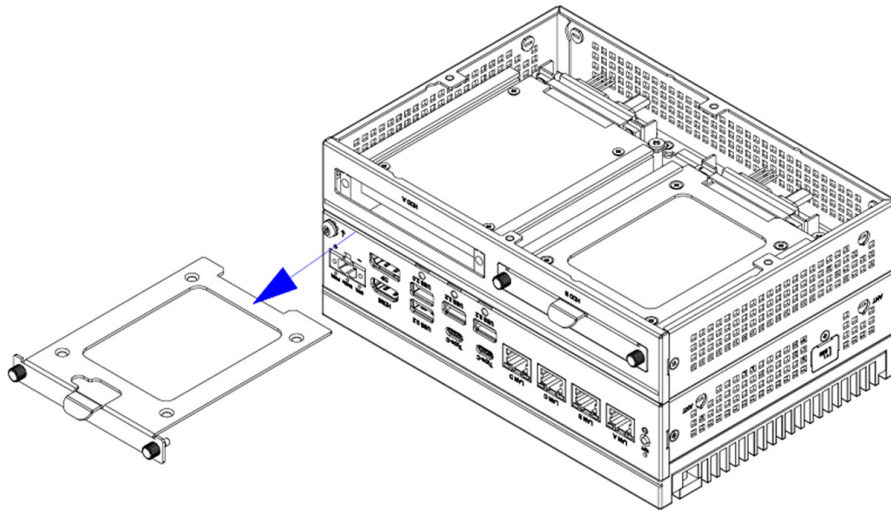

2. Attach the HDD bracket and use the screws (1930008390*4) to fix into the system.

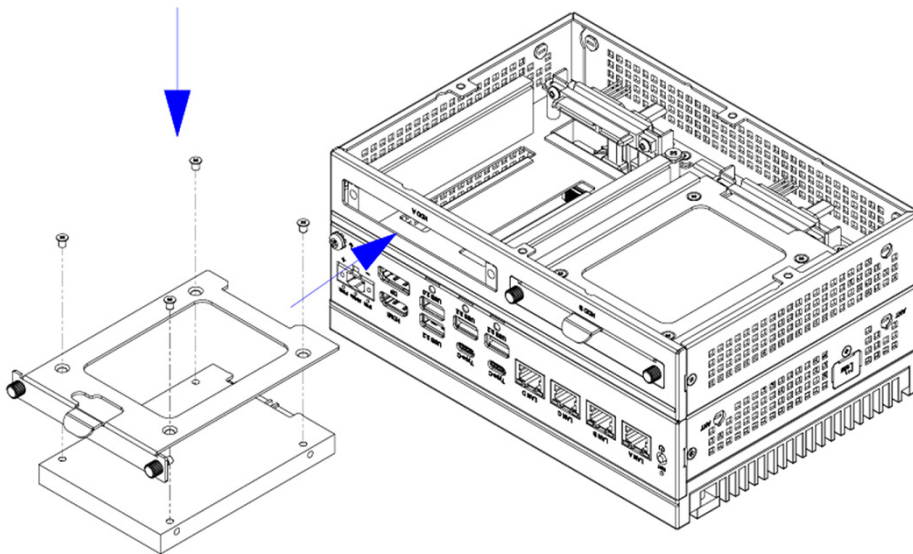

3.9 Install LV2 Expansion (for 2-iDOOR SKU)

1. Release the dummy iDOOR cover.

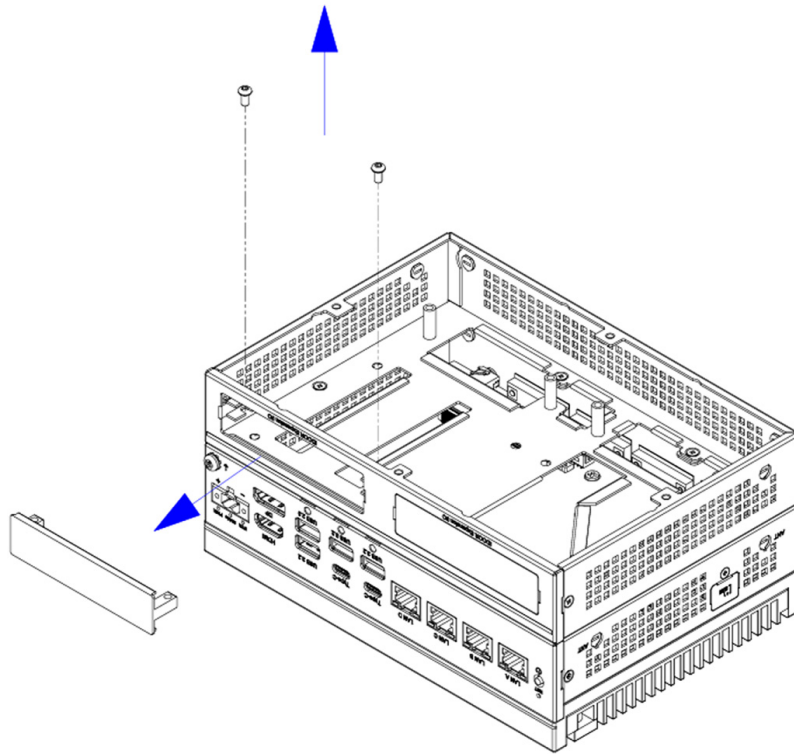

2. Insert the iDOOR module using the screws (1935030600*2) and tighten them onto the system.

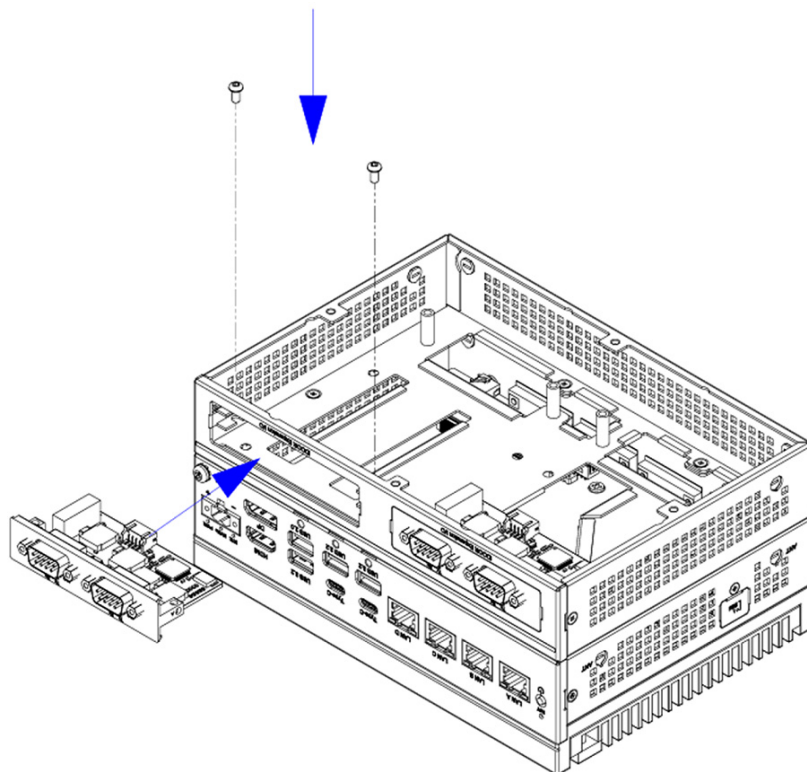

Chapter 4

BIOS Operations

4.1 Introduction

With the AMI BIOS Setup Utility, you can modify BIOS settings and control the specific features of your computer. The Setup Utility uses a number of menus for making changes and turning the specific features on or off. This chapter describes the basic navigation of the UNO-2484V3 setup screens.

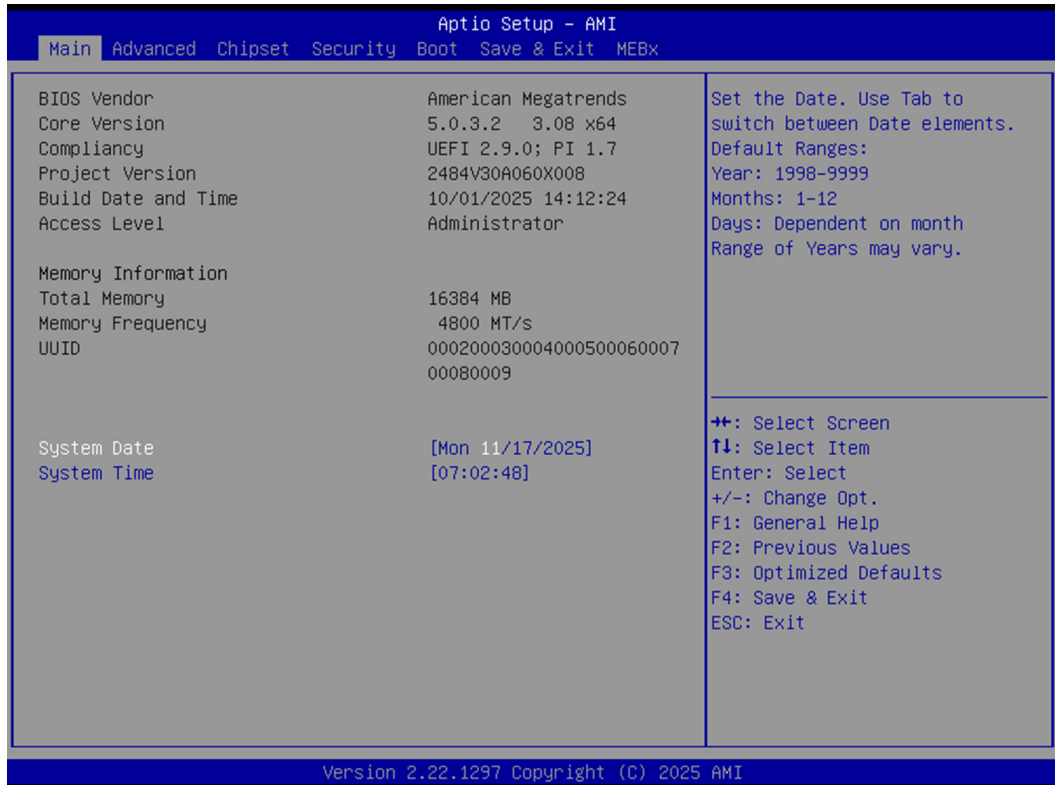

Figure 4.1 Main Setup Screen

AMI BIOS ROM has a built-in Setup program that allows users to modify the basic system configuration. This information is stored in the NVRAM area so it retains the setup information when the power is turned off.

4.2 Entering BIOS Setup

Press to enter the AMI BIOS Setup Utility and the Main Menu will appear on the screen. Use the arrow keys to select menu items, and press <Enter> to confirm a selection or enter a sub-menu.

When users first enter the BIOS Setup Utility, they are taken to the Main Setup screen. Users can always return to the Main Setup screen by selecting the Main tab. There are two Main Setup options described in this section. The Main BIOS Setup screen is shown below.

4.2.1 Main Menu

Press to enter AMI BIOS Setup Utility, the Main Menu will appear on the screen. Use arrow keys to select among the items and press <Enter> to accept or enter the sub-menu.

The Main BIOS setup screen has two main frames. The left frame displays all the options that can be configured. Grayed-out options cannot be configured; options in blue can be. The right frame displays the key legend.

The key legend above is an area reserved for a text message. When an option is selected in the left frame, it is highlighted in white. Often a text message will accompany it.

■ System Time/System Date

Use System time/System date options to change the system time and date.

Highlight System Time or System Date using the keys. Enter new values through the keyboard, press the key or the keys to move between fields. The date must be entered in MM/DD/YY format. The time must be entered in HH:MM:SS format.

4.2.2 Advanced BIOS Features

Setup Select the Advanced tab from the UNO-2484V3 setup screen to enter the Advanced BIOS setup screen. You can select any of the items in the left frame of the screen, such as CPU configuration, to go to the sub menu for that item. You can display an Advanced BIOS Setup option by highlighting it using the keys. All Advanced BIOS Setup options are described in this section. The Advanced BIOS Setup screens are shown below. The sub menus are described on the following pages.



Figure 4.2 Advanced BIOS Features Setup Screen

4.2.2.1 CPU Configuration

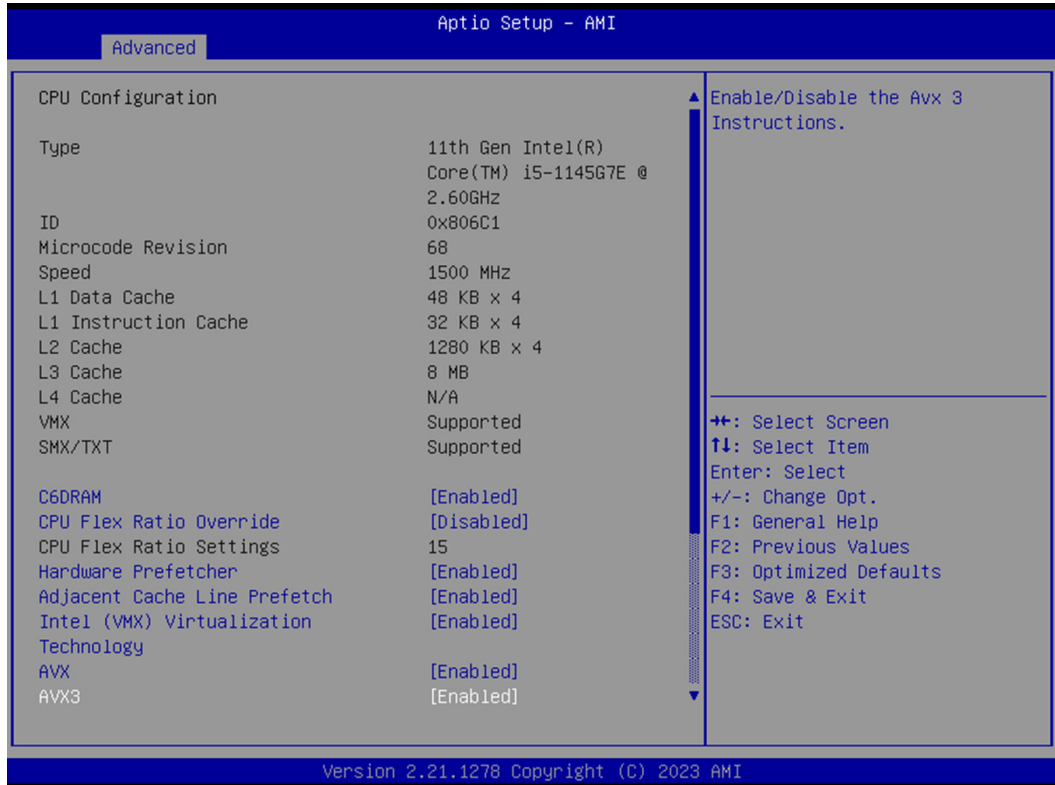

Figure 4.3 CPU Configuration - 1

- **CPU Flex Ration Override**
Enable/Disable CPU Flex Ration Override
- **CPU Flex Ratio Settings**
Enable/Disable CPU Flex Ration Setting change.
- **Intel (VHX) Virtualization Technology**
This feature is used to Enable or Disable VMM which can utilize additional hardware capabilities provided by Vanderpool Technology.
- **AVX**
Enable/Disable the AVX instructions.
- **Hyper-Threading**
Enable/Disable the Hyper-Threading Technology.
- **AES**
Enable/Disable AES (Advanced Encryption Standard).
- **MachineCheck**
Enable/Disable Machine Check.

4.2.2.2 Power & Performance

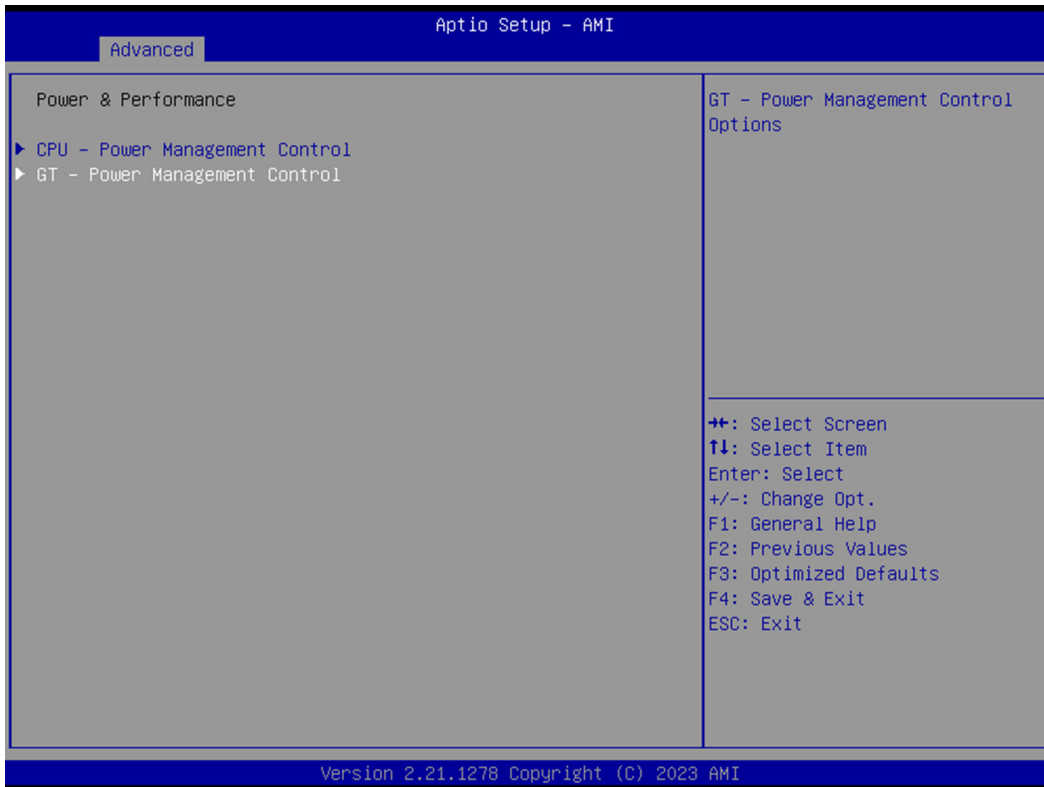

Figure 4.4 Power & Performance-1

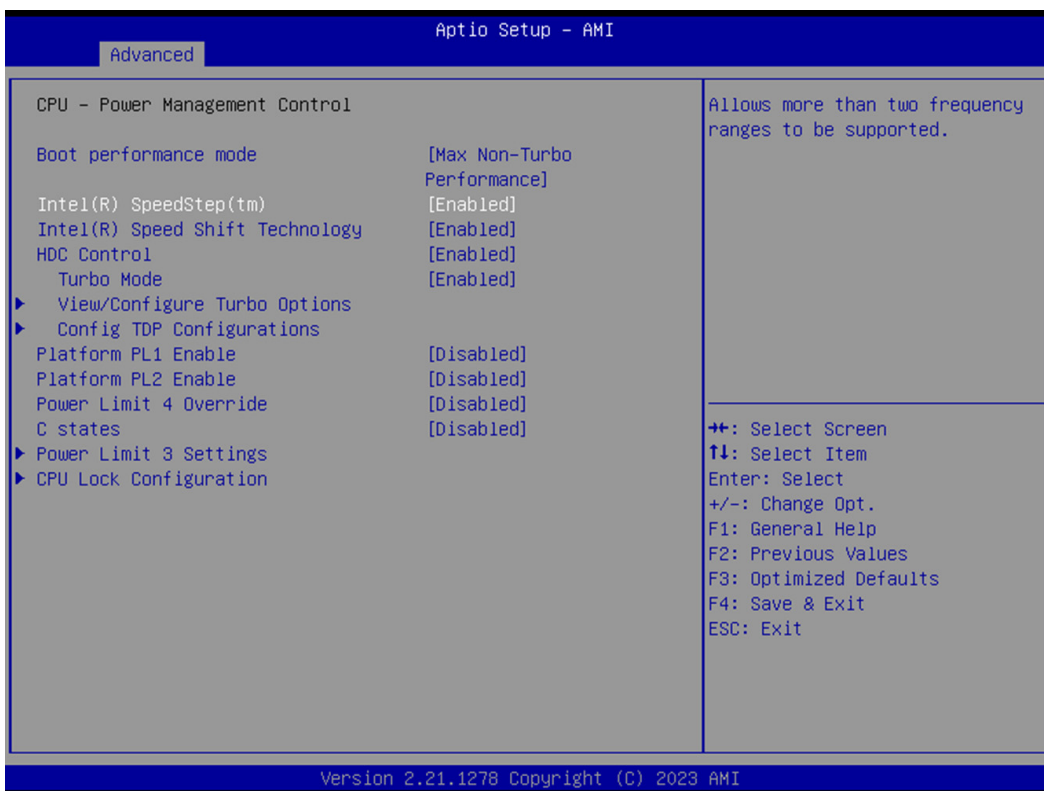

Figure 4.5 CPU - Power Management Control-1

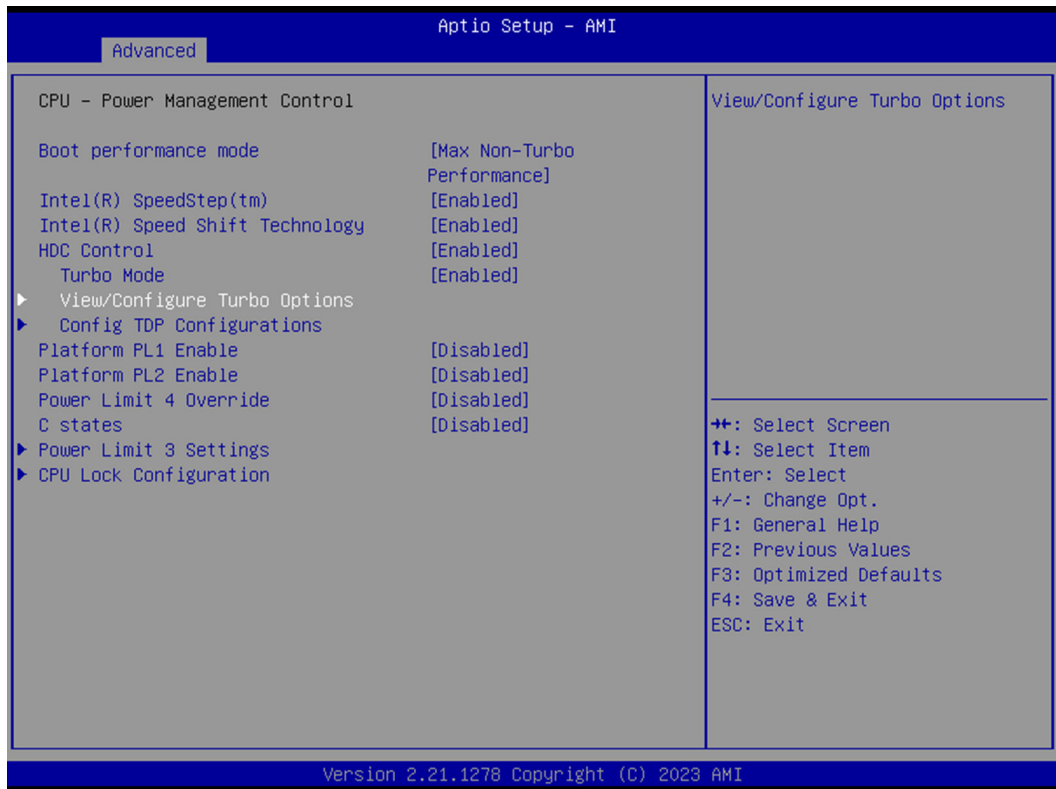

Figure 4.6 View/configure Turbo Option -1

- **Boot Max Frequency**
- **Boot Performance Mode**
- **Intel(R) Speedstep(tm)**
Allows more than two frequency ranges to be supported.
- **Intel(R) Speed Shift Technology**
Enable/Disable Intel(R) Speed Shift Technology support. Enabling will expose the CPPC v2 interface to allow for hardware controlled P-state.

View/ Configure Turbo Option

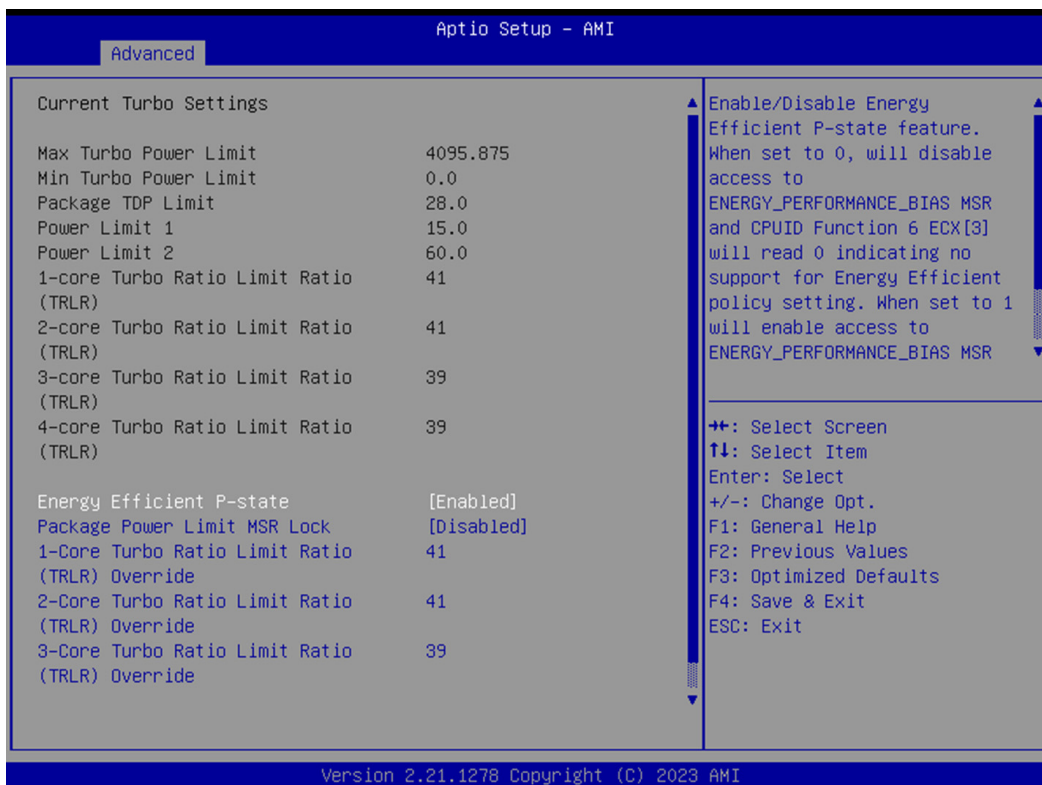

Figure 4.7 View/Configure Turbo Option -2

Config TDP Configurations

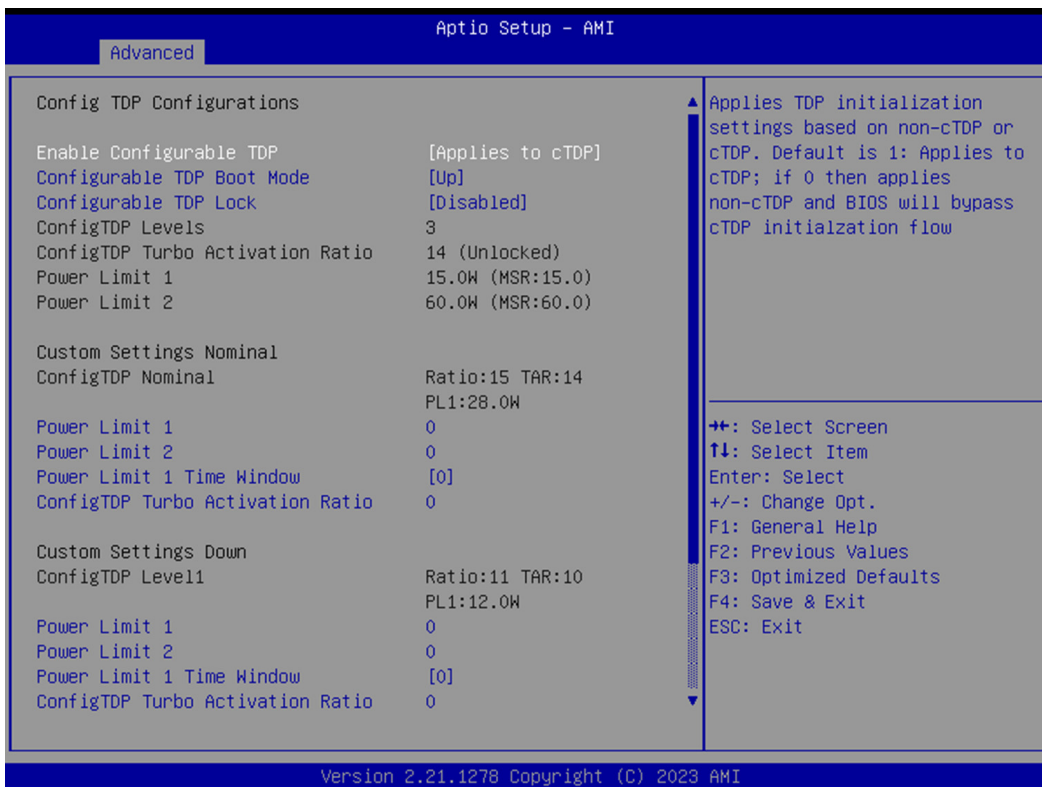

Figure 4.8 Config TDP Configurations

■ **Enable Configurable TDP**

Applies TDP initialization settings based on non-cTDP or cTDP. Default is 1: Applies to cTDP; if 0 then applies non-cTDP and BIOS will bypass cTDP initialization flow.

– **Configurable TDP Boot Mode**

Configurable TDP Mode as Nominal/Up/Down/Deactivation option will set MSR to Nominal and HMIO to Zero.

– **Configurable TDP Lock**

Configurable TDP Mode Lock set the Lock bits on TURBO_ACTIVATION_RATIO and CONFIG_TDP_CONTROL. Note: When cTDP Lock is enabled Custom ConfigTDP Count will be forced to 1 and Custom ConfigTDP Boot Index will be forced to 0.

– **Power Limit 1**

Power Limit 1 in Milli Watts. BIOS will round to the nearest 1/8W when programming. 0= no custom override. For 12.50W, enter 12500. Overclocking SKU: Value must be between Max and Min Power Limits (specified by PACKAGE_POWER_SKU_MSR). Other SKUs: This value must be between Min Power Limit and TDP Limit.

– **Power Limit 2**

Power Limit 2 in Milli Watts. BIOS will round to the nearest 1/8W when programming. 0= no custom override. For 12.50W, enter 12500. Processor applies control policies such that the package power does not exceed this limit.

– **ConfigTDP Turbo Activation Ratio**

Custom value for Turbo Activation Ratio. Needs to be configured with valid values from LFM to Max Turbo. 0 means don't use custom value.

– **Power Limit 1 Time Window**

Power Limit 1 Time Window value in seconds. The value may vary from 0 to 128. 0 = default value (28 sec for Mobile and 8 sec for Desktop). Defines time window which TDP value should be maintained.

– **ConfigTDP Turbo Activation Ratio**

Custom value for Turbo Activation Ratio. Needs to be configured with valid values from LFM to Max Turbo. 0 means don't use custom value.



Figure 4.9 GT – Power Management Control

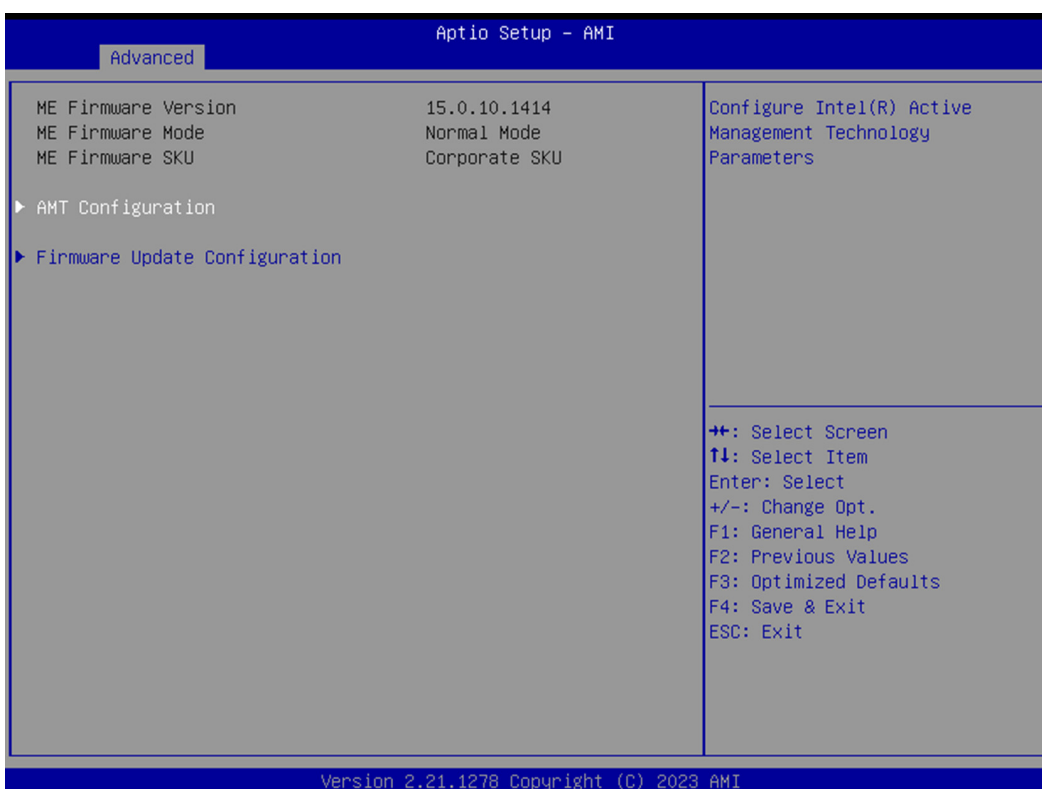

Figure 4.10 ME State

- **Manageability Features State**

When disabled, ME will be put into ME Temporarily Disabled mode.

- **AMT BIOS Features**

- **AMT Configuration**

Configure Intel® Active Management Technology Parameters.

- ME Unconfig on RTC Clear
- Core BIOS Done Message
- Firmware Update Configuration

4.2.2.3 TPM Device Selection

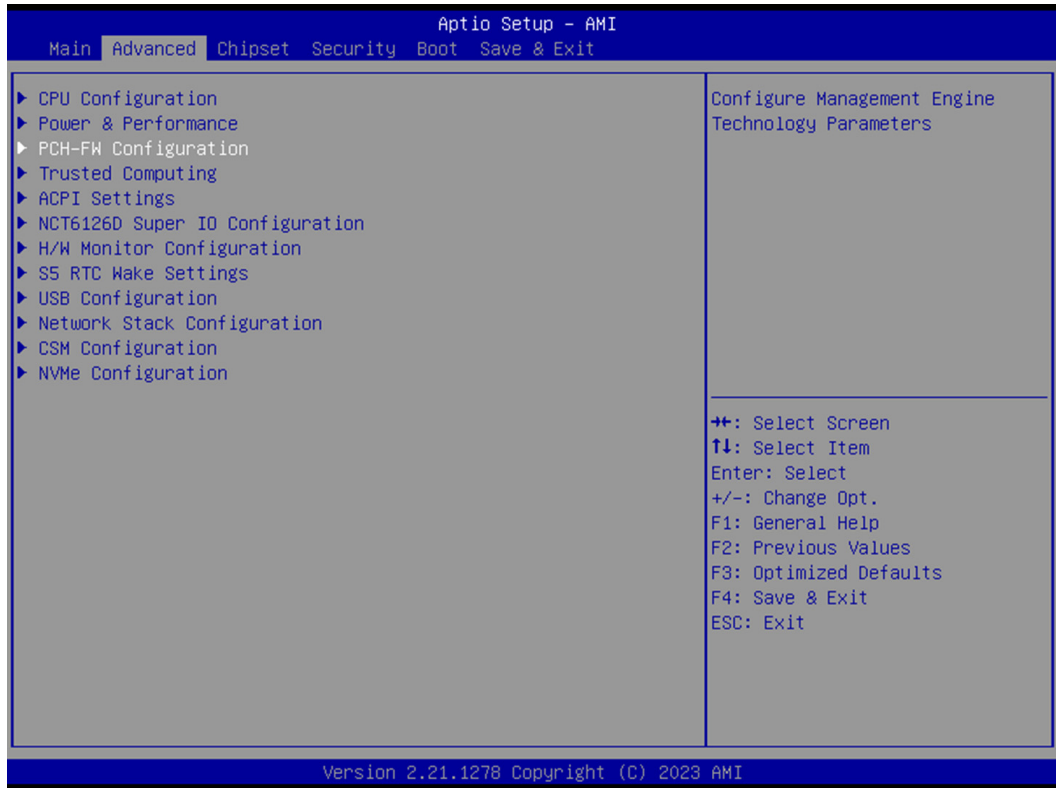

Figure 4.11 TPM Device Configuration -1

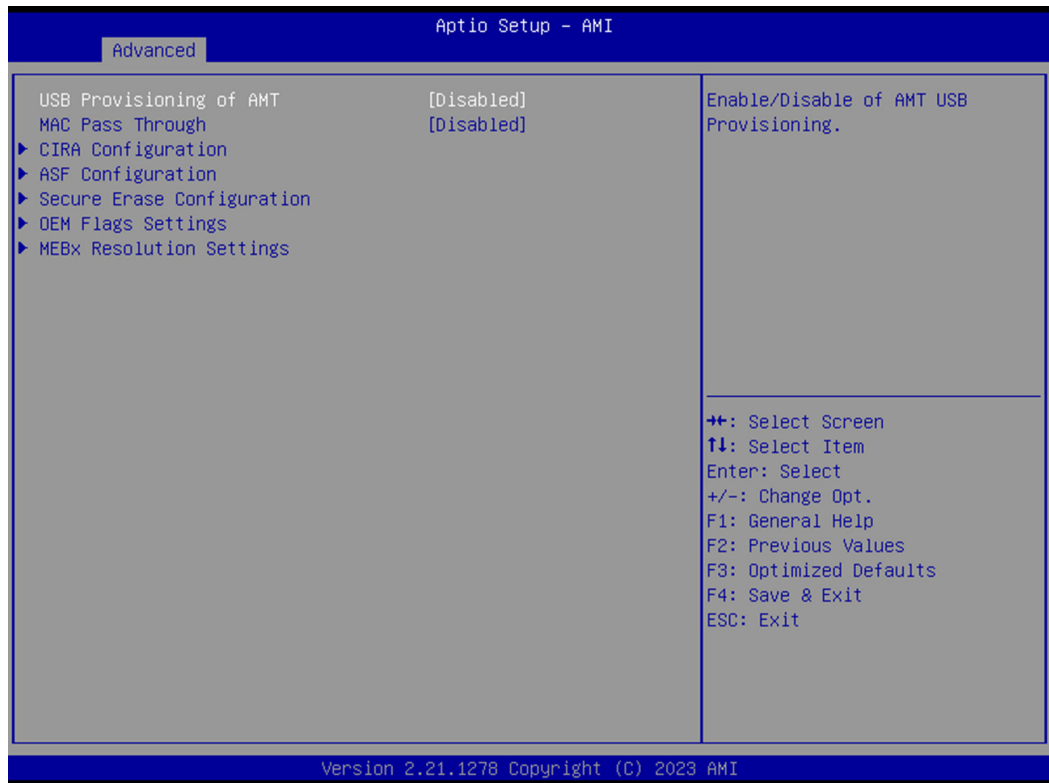

Figure 4.12 TPM Device Configuration - 2

- **USB Provisioning of AMT**
Enable/Disable ANT USB Provisioning.
- **Activate Remote Assistance Process**
- **Unconfigure ME**
- **Trusted Computing**

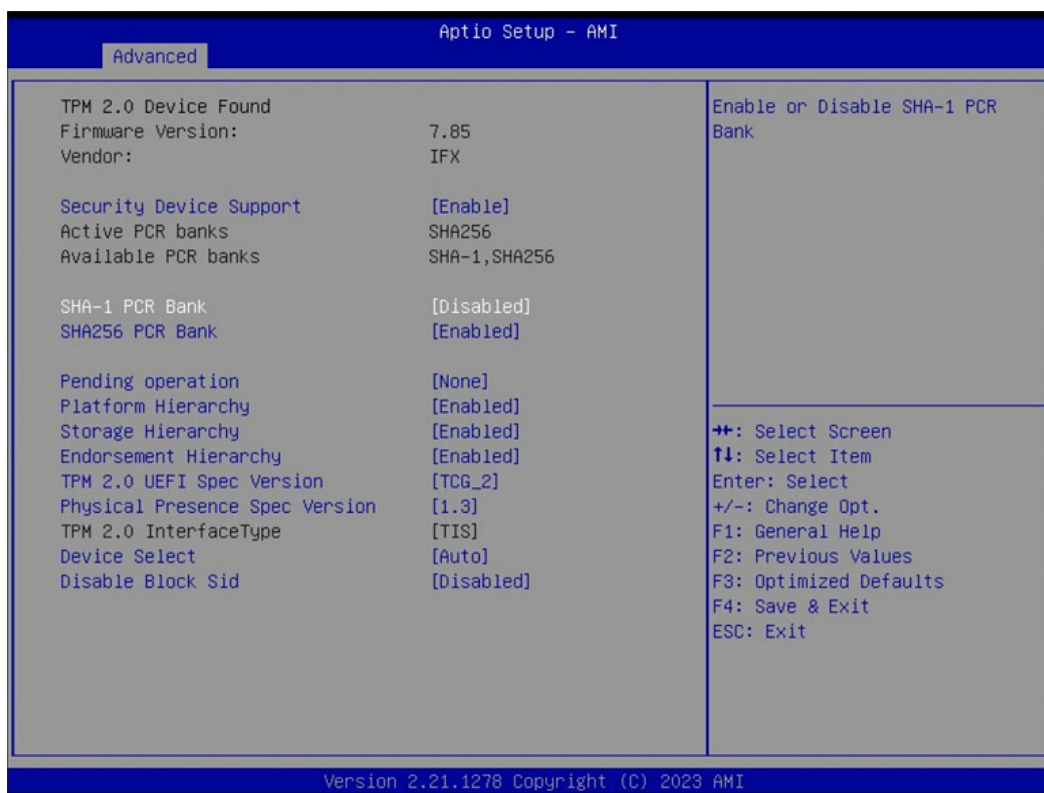

Figure 4.13 Trusted Computing-2

- **SHA-1 PCR Bank**
Enable/Disable SHA-1 PCR Bank.
- **SHA256 PCB Bank**
Enable/Disable SHA-256 PCR Bank.
- **Pending Operation**
Schedule an Operation for the Security Device. NOTE: Your Computer will reboot during restart in order to change state of Security Device.
- **Platform Hierarchy**
Enable/Disable Platform Hierarchy.
- **Storage Hierarchy**
Enable/Disable Storage Hierarchy.
- **Endorsement Hierarchy**
Enable/Disable Endorsement Hierarchy.
- **TPM 2.0 UEFI SPEC Version**
Select the TCG2 Spec Version Support.
TCG_1_2: The compatible mode for Win8/Win10
TCG_2: Supports new TCG2 protocol and event format for Win10 or later.
- **Physical Presence Spec Version**
Select to tell OS to support PPI Spec Version 1.2 or 1.3. Note some HCK tests might not support 1.3.
- **Device Select**

TPM 1.2 will restrict support to TPM 1.2 devices, TPM 2.0 will restrict support to TPM 2.0 devices, Auto will support both with the default set to TPM 2.0 devices if not found, TPM 1.2 devices will be enumerated.

– **Disable Block Sid**

Override to allow SID authentication in TCG Storage device.

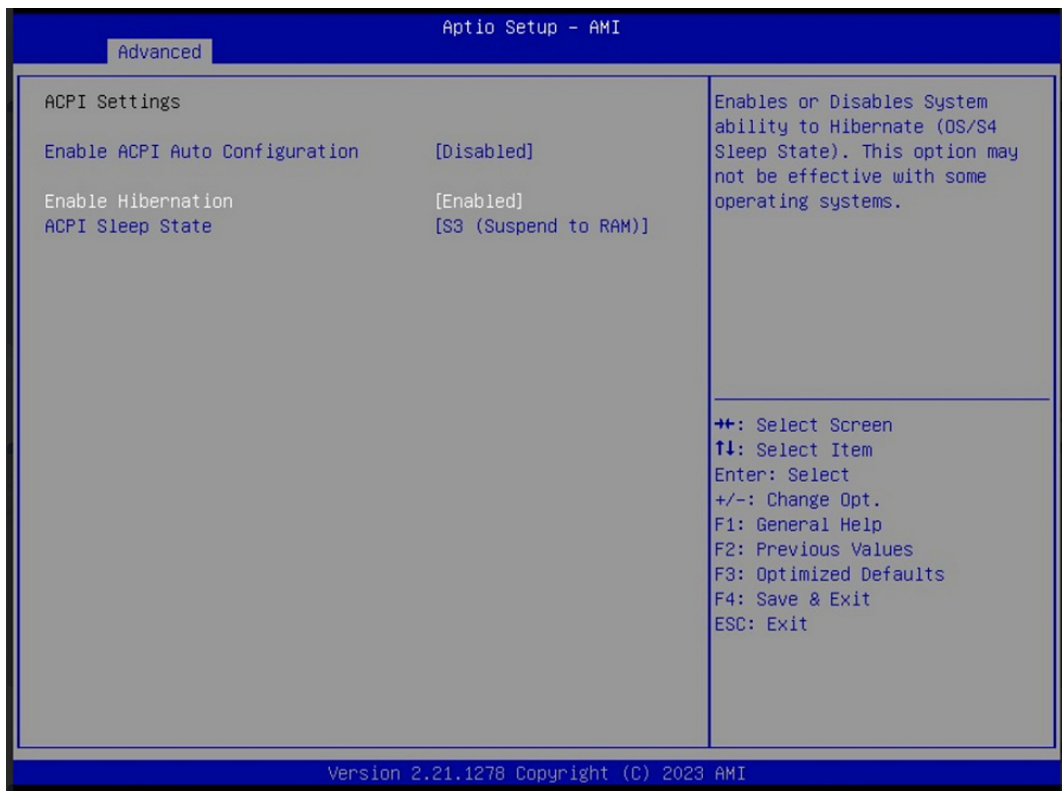

Figure 4.14 ACPI Setting -1

■ **ACPI Settings**

System ACPI Parameters.

– **Enable ACPI Auto Configuration**

Default is disabled.

– **Enable Hibernation**

Enable/Disable System ability to Hibernate (OS/S4 Sleep State). This option may not be effective with some operating systems.

– **ACPI Sleep State**

Select the highest ACPI sleep state the system will enter when the SUSPEND button is pressed.

■ NCT61260 Super IO Configuration

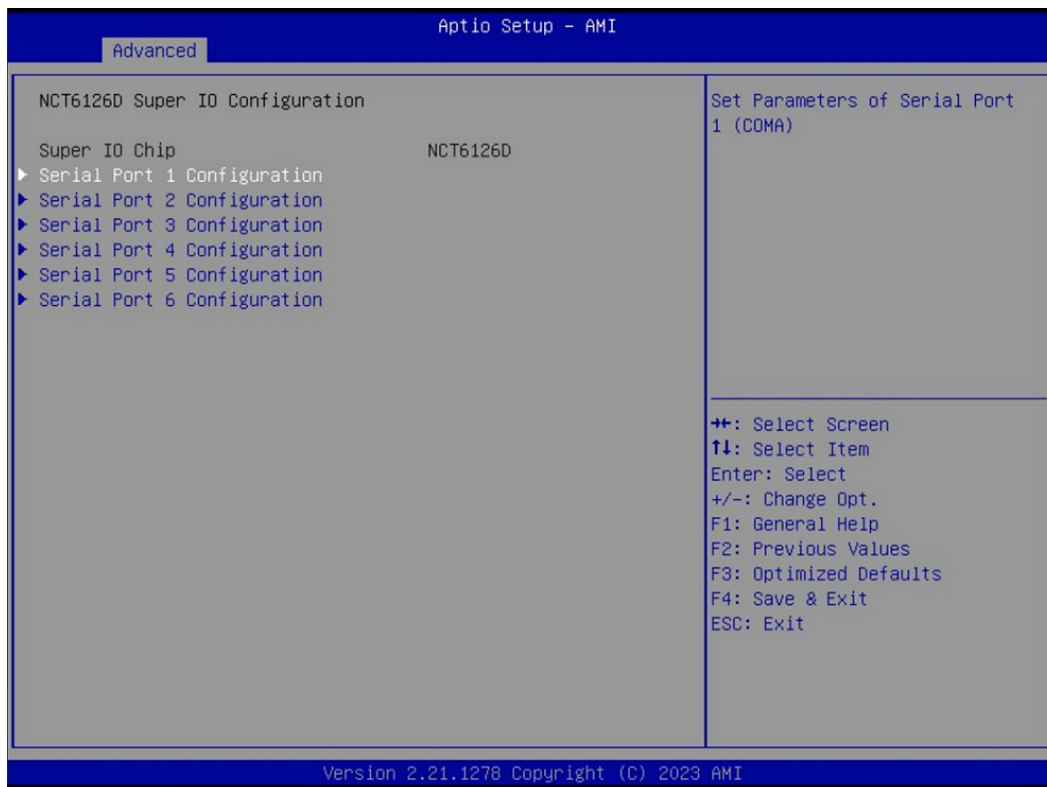

Figure 4.15 NCT61260 Super IO Configuration

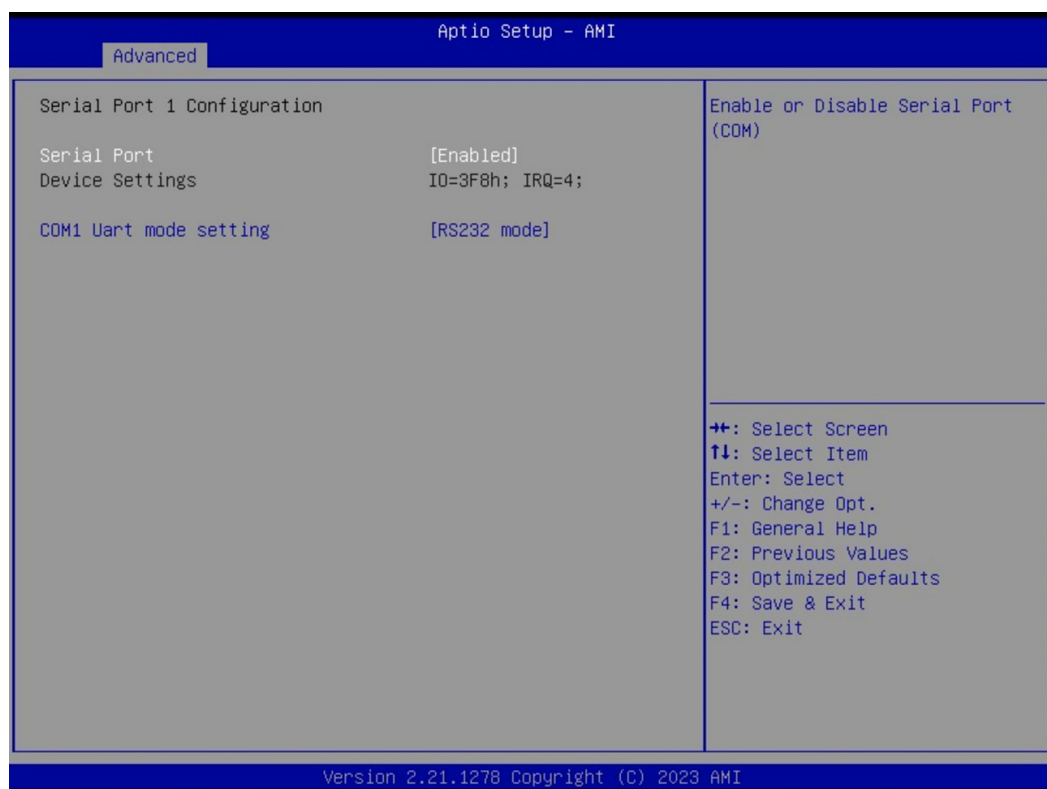

Figure 4.16 NCT61260 Super IO Configuration

-
- **Super IO Chip NCT61260**
 - **Serial Port 1 Configuration**
Set Parameters of Serial Port 1 (COMA).
 - **Serial Port**
Enable/Disable Serial Port (COM).
 - **COM1 Uart mode Setting**
RS232/ RS422/ RS485 mode.
 - **Serial Port 2 Configuration**
Set Parameters of Serial Port 2 (COMB).
 - **Serial Port**
Enable/Disable Serial Port (COM).
 - **COM2 Uart mode Setting**
RS232/ RS422/ RS485 mode.
 - **Serial Port 3 Configuration**
Set Parameters of Serial Port 3 (COMC).
 - **Serial Port**
Enable/Disable Serial Port (COM).
 - **COM3 Uart mode Setting**
RS232/ RS422/ RS485 mode.
 - **Serial Port 4 Configuration**
Set Parameters of Serial Port 4 (COMD).
 - **Serial Port**
Enable/Disable Serial Port (COM).
 - **COM1 Uart mode Setting**
RS232/ RS422/ RS485 mode.
 - **Serial Port 5 Configuration**
Set Parameters of Serial Port 5 (COME).
 - **Serial Port**
Enable/Disable Serial Port (COM).
 - **Serial Port 6 Configuration**
Set Parameters of Serial Port 6 (COMF).
 - **Serial Port**
Enable/Disable Serial Port (COM).

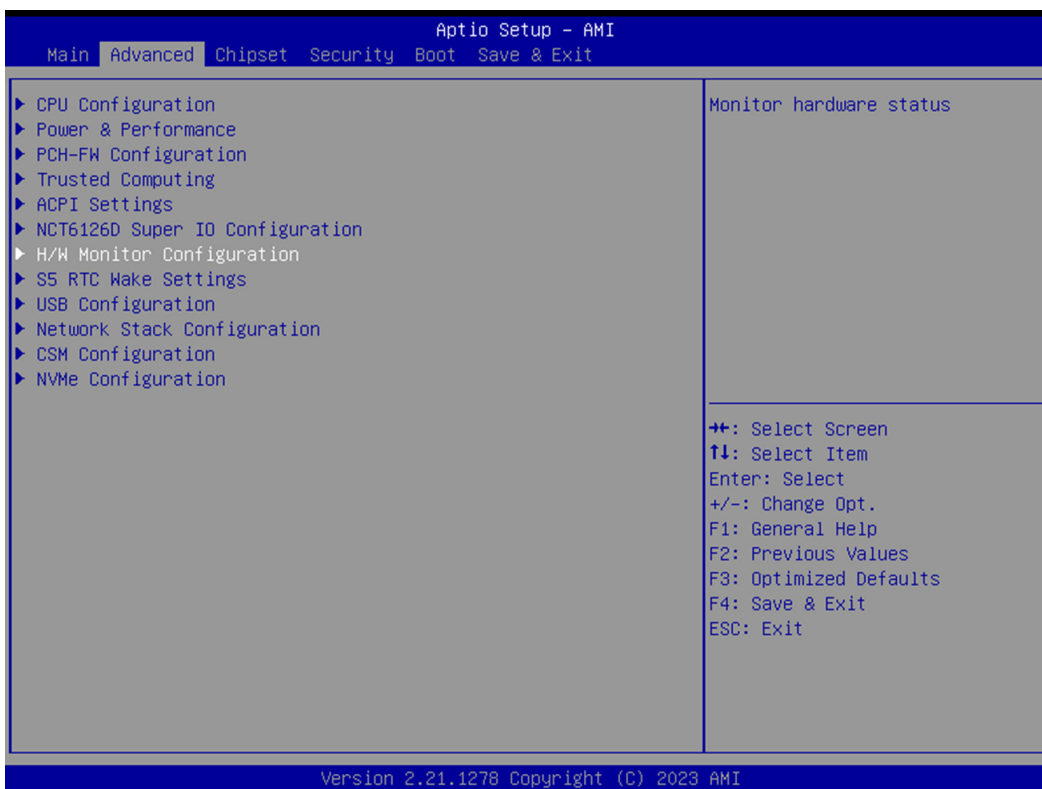

Figure 4.17 H/W Monitor Configuration-1

- **PC Health Status**
- **CPU Temperature**
- **System Ambient**

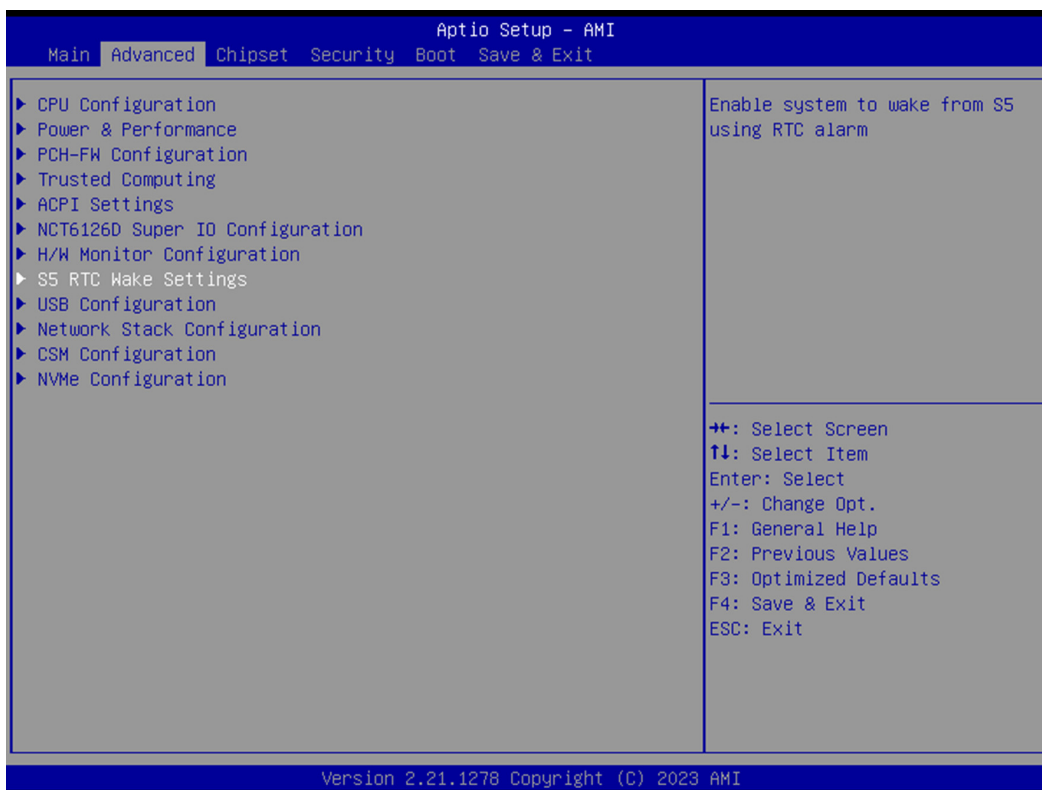

Figure 4.18 S5 RTC Make Settings -1

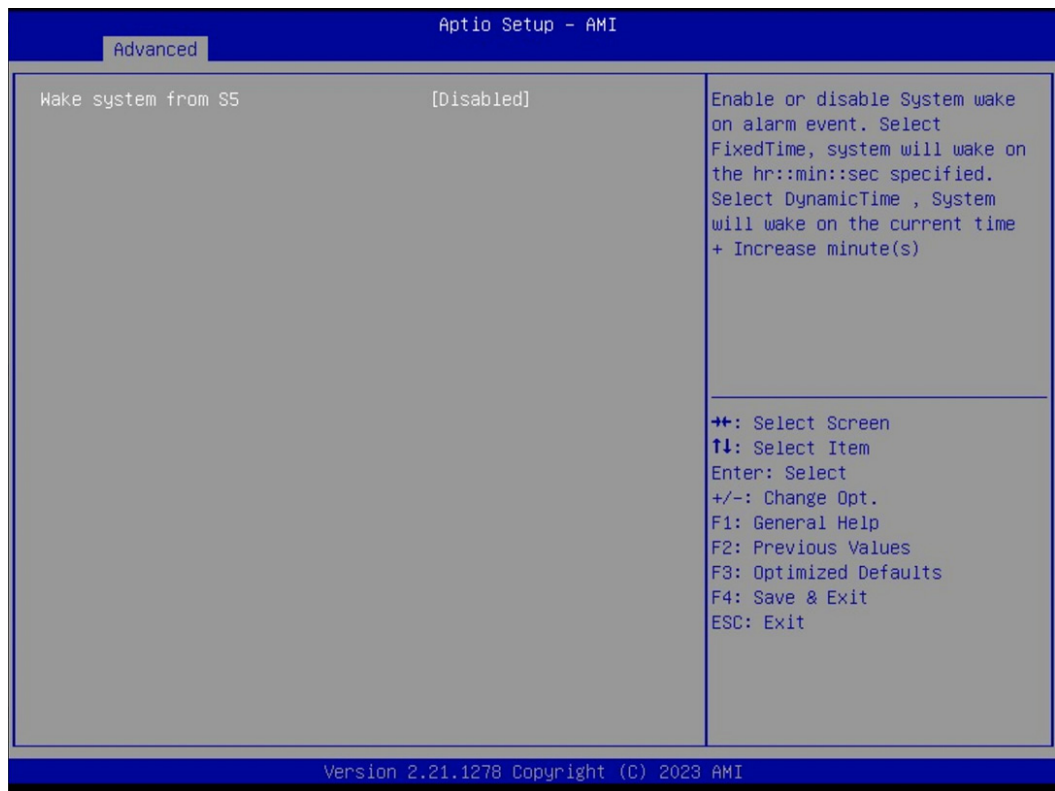

Figure 4.19 S5 RTC Make Settings -2

- **S5 RTC Make Settings**

Enable system to wake from S5 using RTC alarm

- **Wake System from S5**

Enable/Disable System wake on alarm event. Select FixedTime, system will wake on the hr::min::sec specified. Select DynamicTime, System will wake on current time + Increase minute(s).

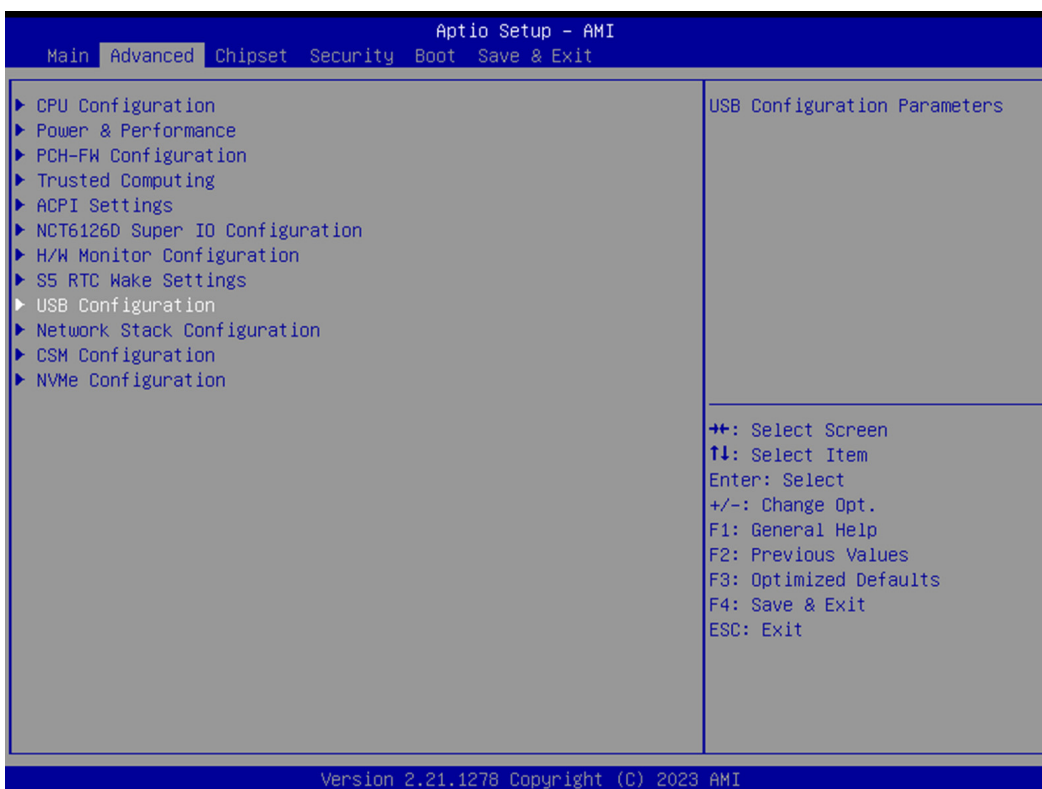

Figure 4.20 USB Configuration -1

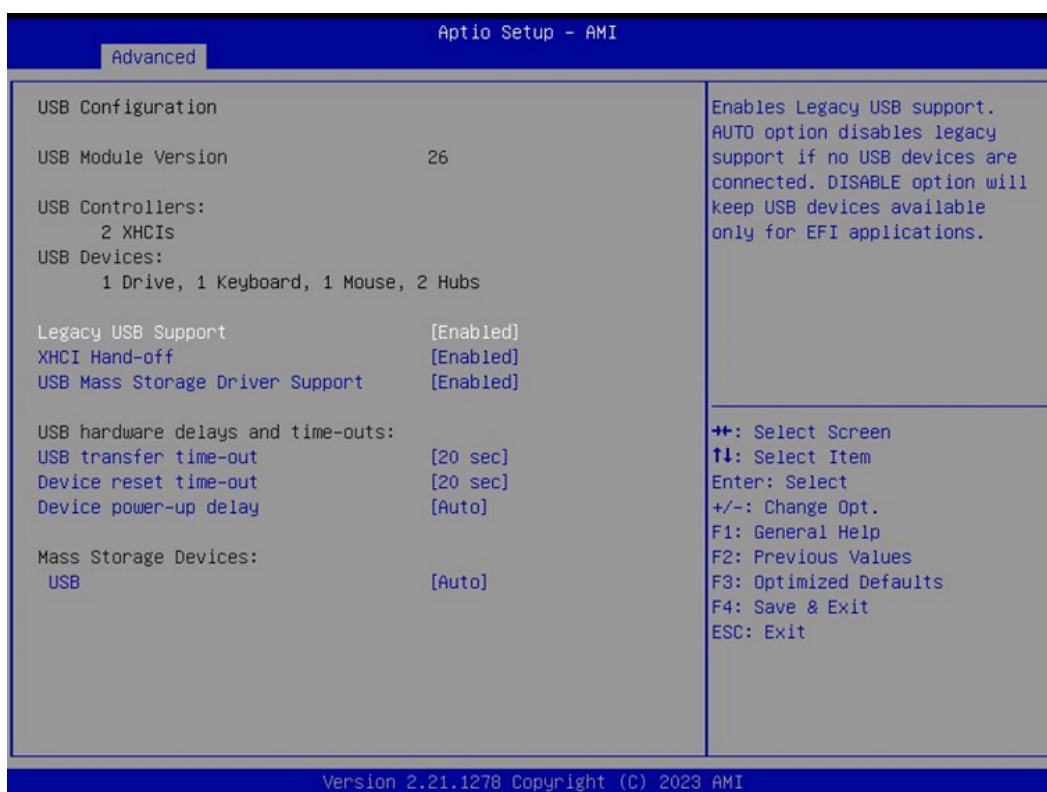

Figure 4.21 USB Configuration-2

- **USB Configuration**
 - USB Configuration Parameters.
 - **Legacy USB Support**

Enable Legacy USB Support. AUTO option disable legacy support if no USB devices are connected. DISABLE option will keep USB devices available only for EFI applications.

- **XHCI Hand-off**

This is a workaround for OS without XHCI hand-off support. The XHCI ownership change should be claimed by XHCI driver.

- **USB Mass Storage Driver Support**

Enable/ Disable USB Mass Storage Driver Support.

- **USB hardware Delays and Time-outs**

- **USB Transfer Time-out**

The time-out value for Control, Bulk, and Interrupt transfers.

- **Device Power-up Delay**

Maximum time the device will take before it properly reports itself to the Host Controller. "Auto" uses default value: for a Root port it is 100ms, for a Hub port the delay is taken from descriptor.

- **Mass Storage Devices: USB**

Mass storage device emulation type. "AUTO" enumerates devices according to their media format. Optical drives are emulated as "CDROM", drives with no media will be emulated according to a drive type.



Figure 4.22 Network Stack Configuration - 1

- **Network Stack Configuration**

Network Stack Settings.

- **Network Stack**

Enable/ Disable UEFI Network Stack

- **IPv4 PXE Support**

Enable/ Disable IPv4 PXE boot support. If disabled, IPv4 PXE boot support will not be available.

- **IPv4 HTTP Support**

- Enable/ Disable IPv4 HTTP boot support. If disabled, IPv4 HTTP boot support will not be available
- **IPv6 PXE Support**
Enable/ Disable IPv6 PXE boot support. If disabled, IPv6 PXE boot support will not be available.
- **IPv6 HTTP Support**
Enable/ Disable IPv6 HTTP boot support. If disabled, IPv6 HTTP boot support will not be available.
- **PXE Boot Wait Time**
Wait time in seconds to press ECS key to abort the PXE boot. Use either +/- or numeric keys to set the values.
- **Media Detect Count**
Number of times the presence of media will be checked. Use either +/- or numeric keys to set the value.



Figure 4.23 NVMe Configuration -1

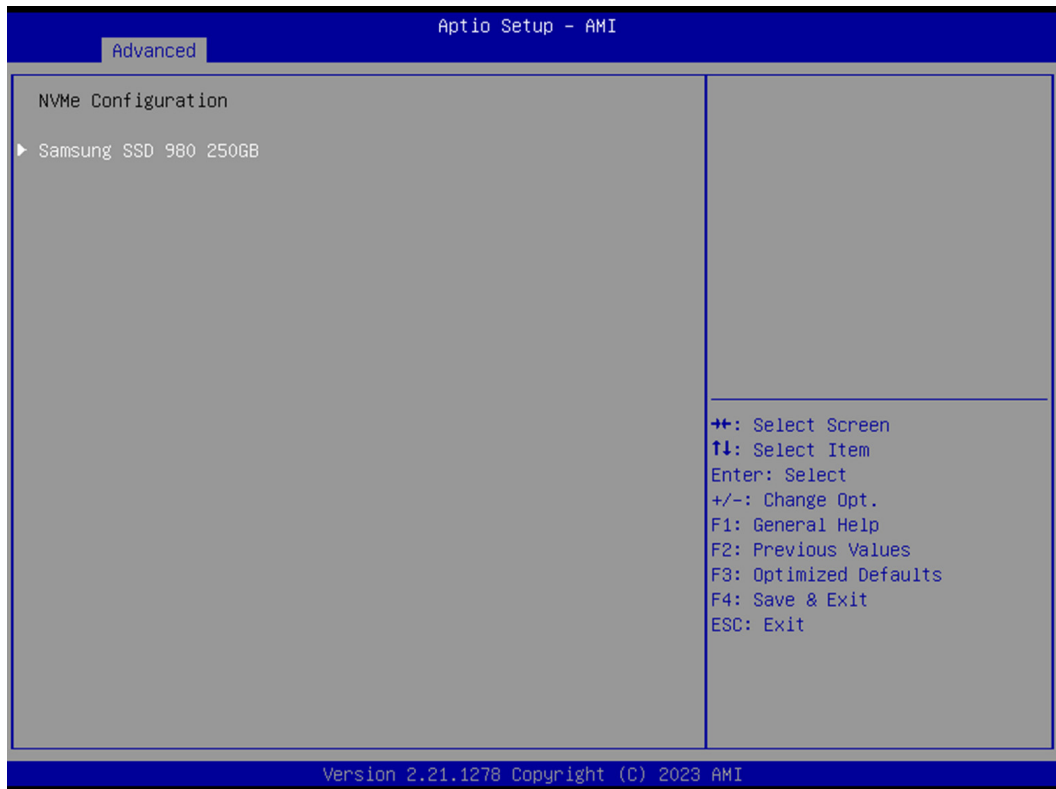

Figure 4.24 NVMe Configuration-2

- **NVMe Configuration**
NVMe Device Option Settings.

4.3 Chipset

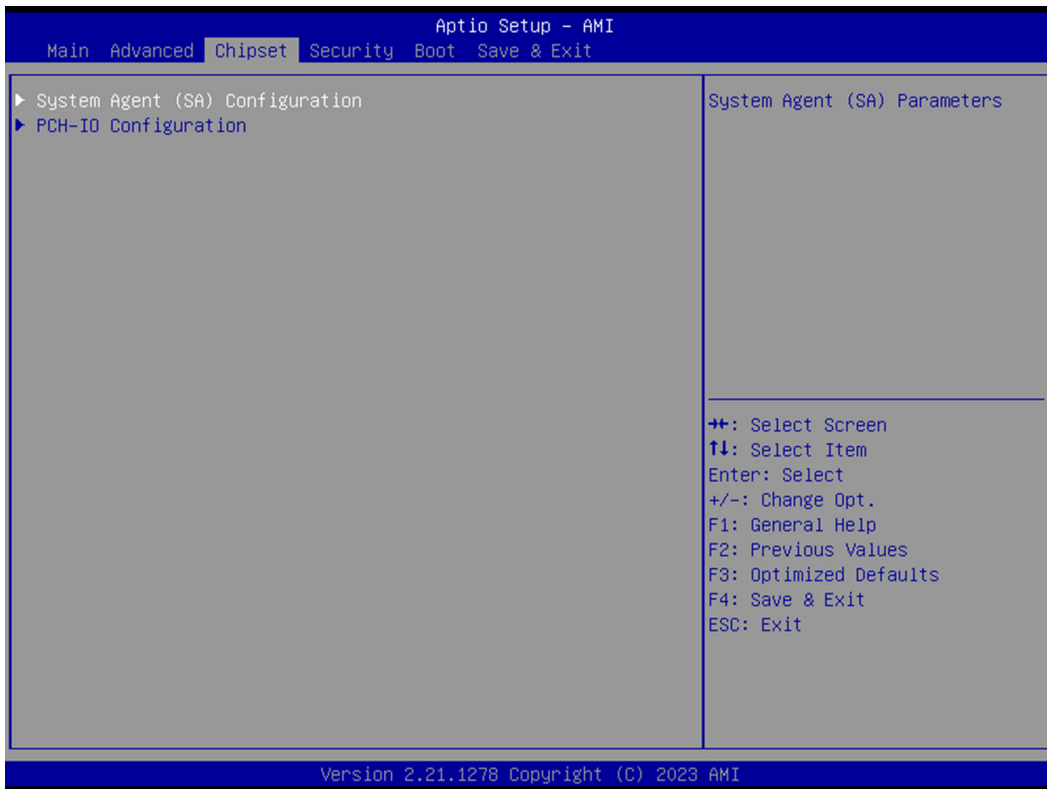

Figure 4.25 System Agent (SA) Configuration - 1

- **System Agent (SA) Configuration**
System Agent (SA) Parameters.

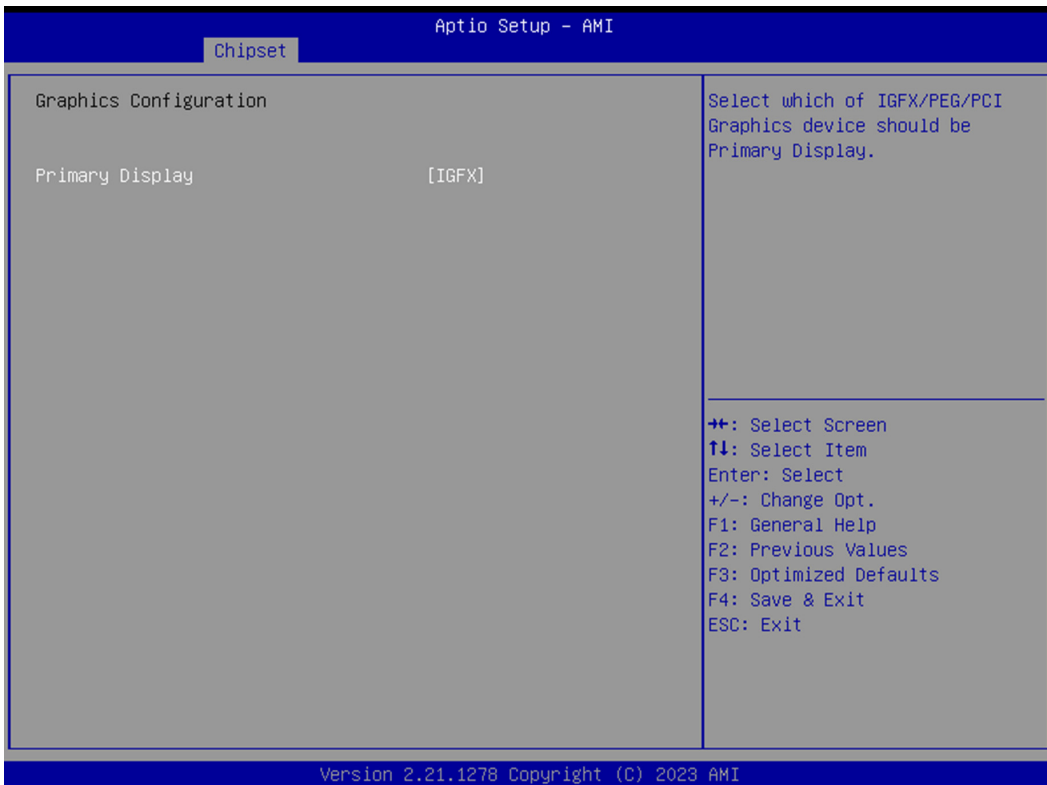

Figure 4.26 Memory Configuration

- **Memory Configuration**

- VMD Setup Menu**

- VT-d Setup Menu**

- Primary Display**

- Select which of the IGFX/PEG/PCI Graphics devices should be the primary display.



Figure 4.27 VMD Setup Menu

- **VMD Setup Menu**

- VMD configuration settings.

- Enable VMD Controller**

- Enable/ disable to VMD controller.

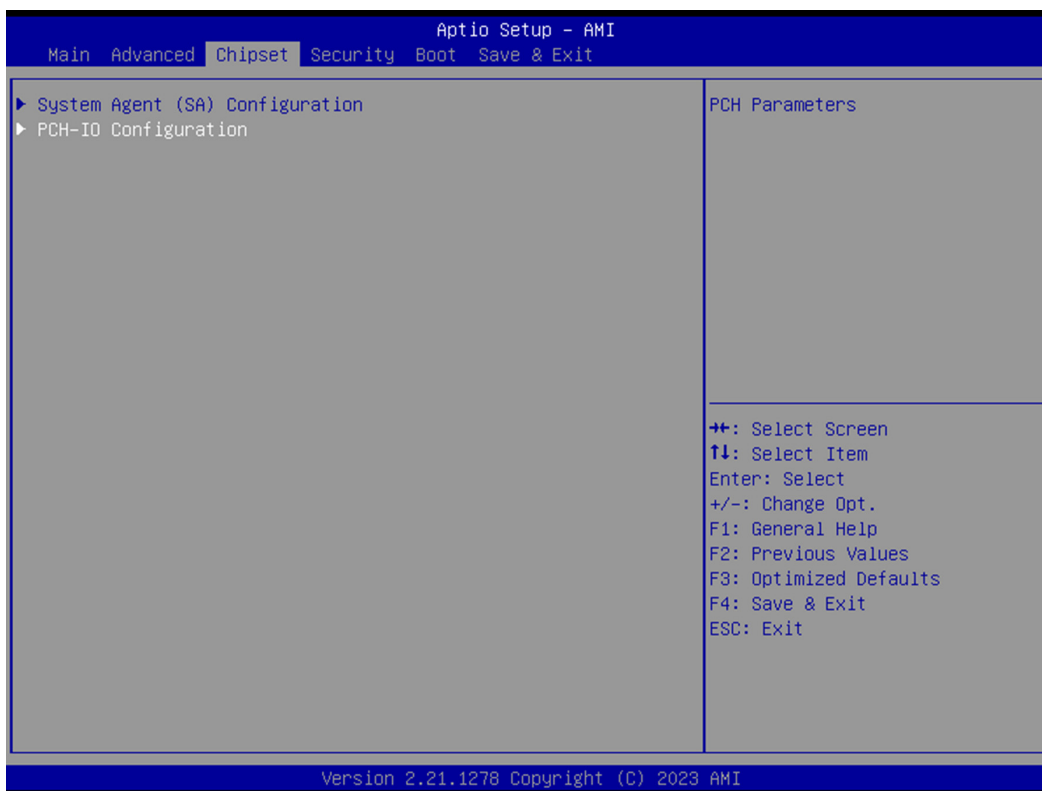

Figure 4.28 SATA Configuration - 1

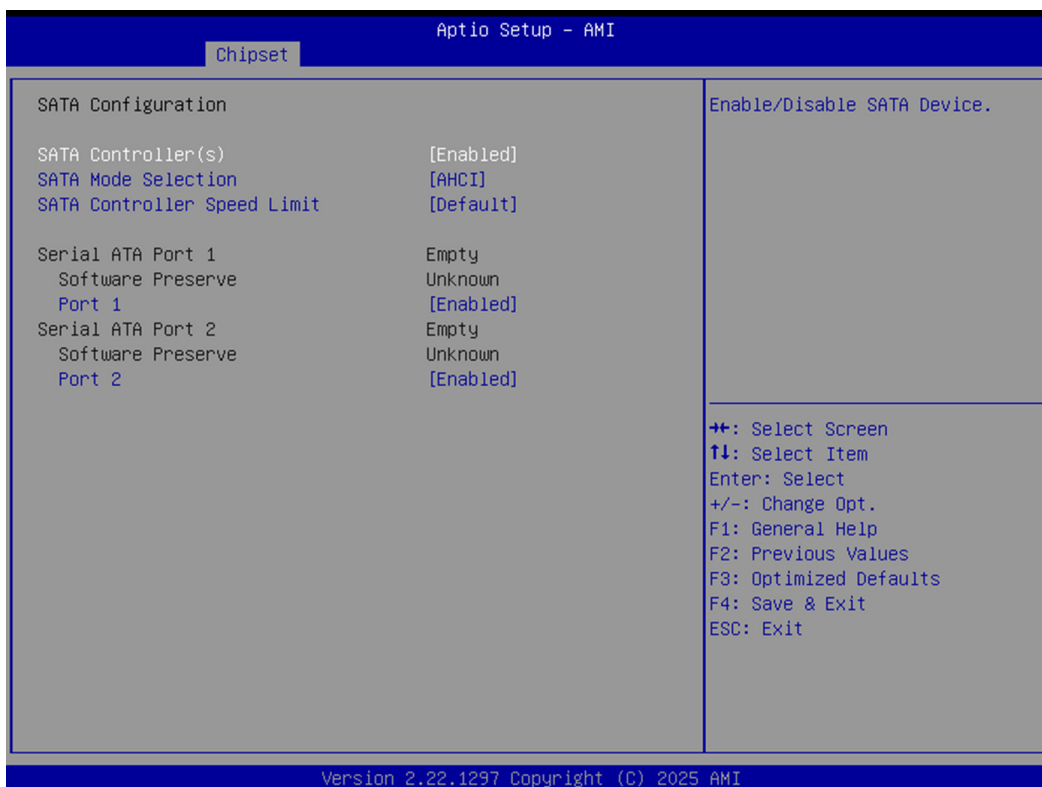

Figure 4.29 SATA Configuration -

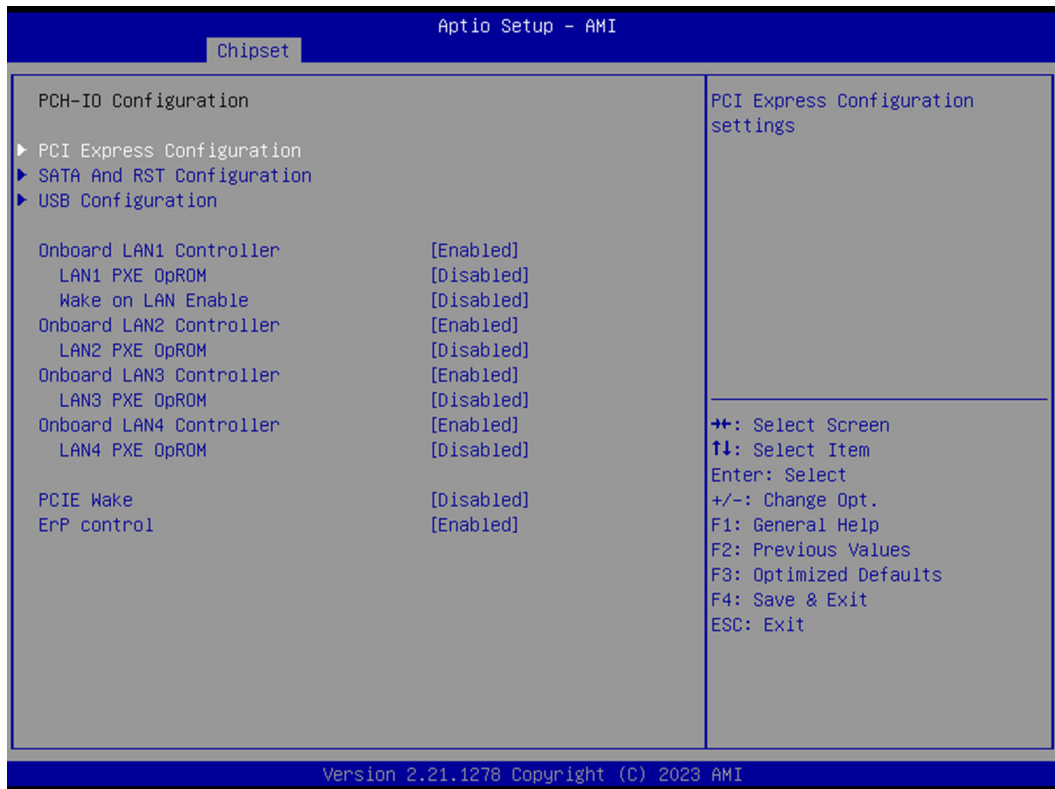

Figure 4.30 PCH-IO Configuration – 2

- **PCI Express Configuration**
PCI Express Configuration settings.
- **SATA and RST Configuration**
SATA Device Options Settings.
 - **SATA Controller(s)**
Enable/ Disable SATA Device.
 - **SATA Mode Selection**
Determines how SATA controller(s) operate.
 - **SATA Controller Speed**
Indicates the maximum speed the SATA controller can support.
 - **Topology**
Identify the SATA Topology if it is Default or ISATA or Flex or DirectConnect or M2.
 - **Port 0**
Enable/Disable SATA Port.
 - **Hot Plug**
Designated this port as Hot Pluggable.
 - **External**
Marks this port as external.
 - **Spin Up Device**
If enabled for any of ports Staggered Spin Up will be performed and only the drives which have this option enabled will spin up at boot. Otherwise all drives spin up at boot.
 - **SATA Device Type**
Identify the SATA port is connected to Solid State Drive or Hard Disk Drive.
 - **SATA Port 0 DevSip**

Enable/ Disable SATA Port 0 DevSip. For DevSip to work, both hard drive and SATA port need to support DevSip function, otherwise an unexpected behavior might happen. Please check board design before enabling it.

– **DITO Configuration**

Enable/ Disable DITO Configuration.

■ **USB Configuration**

USB Configuration settings.

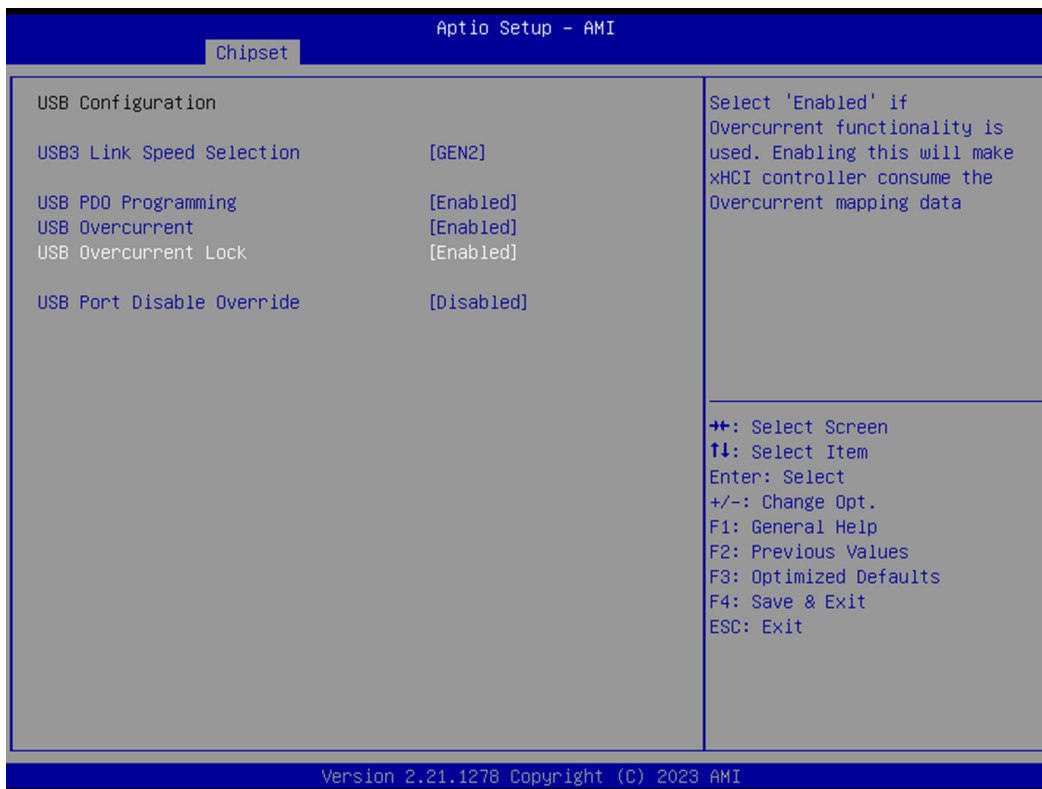

Figure 4.31 USB Configuration

■ **USB Port Disable Override**

Selectively Enable/ Disable the corresponding USB port from reporting a Device Connection to the controller.

4.4 Security

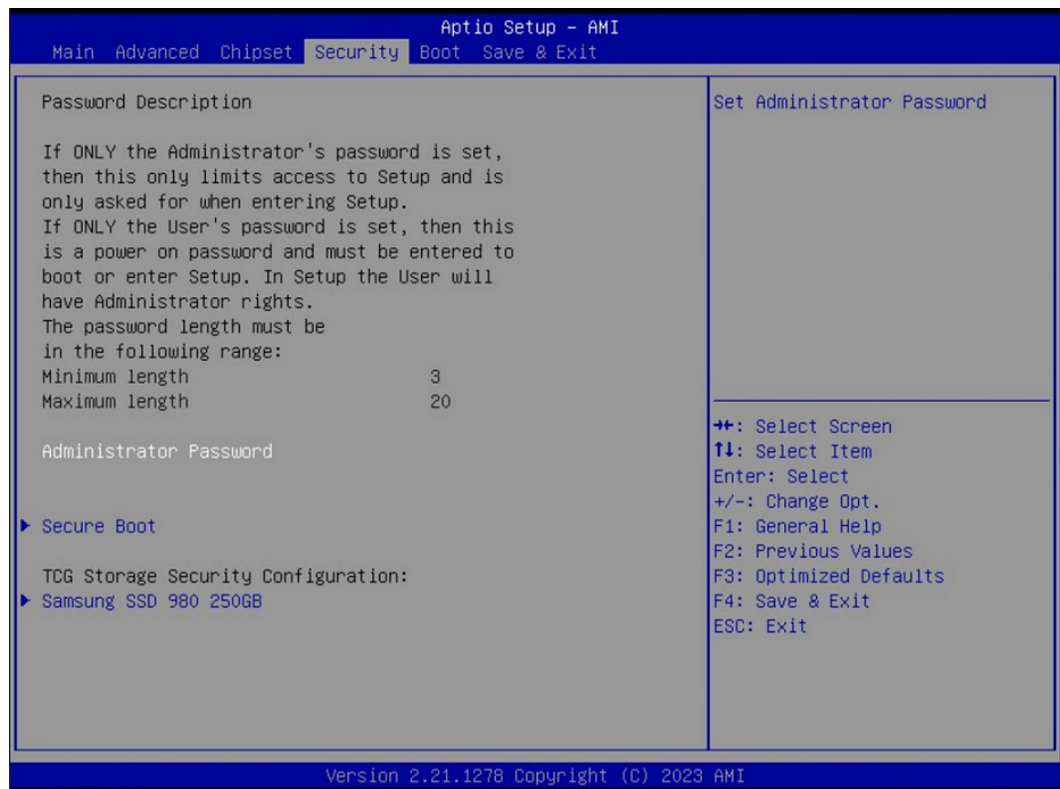

Figure 4.32 Security



Figure 4.33 Secure Boot - 1

- **Administrator Password**
Set Administrator Password.

- **Security Boot**

Secure Boot feature is Active if Secure Boot is Enabled. Platform Key (PK) s enrolled and the System is in User mode. The mode change requires platform reset.

- **Secure Boot Mode**

Secure Boot mode options: Standard or Custom. In Custom mode, Secure Boot Policy variables can be configured by a physically present user without full authentication.

- **Restore Factory Keys**

Forces the system into User Mode. Installs factory default Secure Boot key databases.

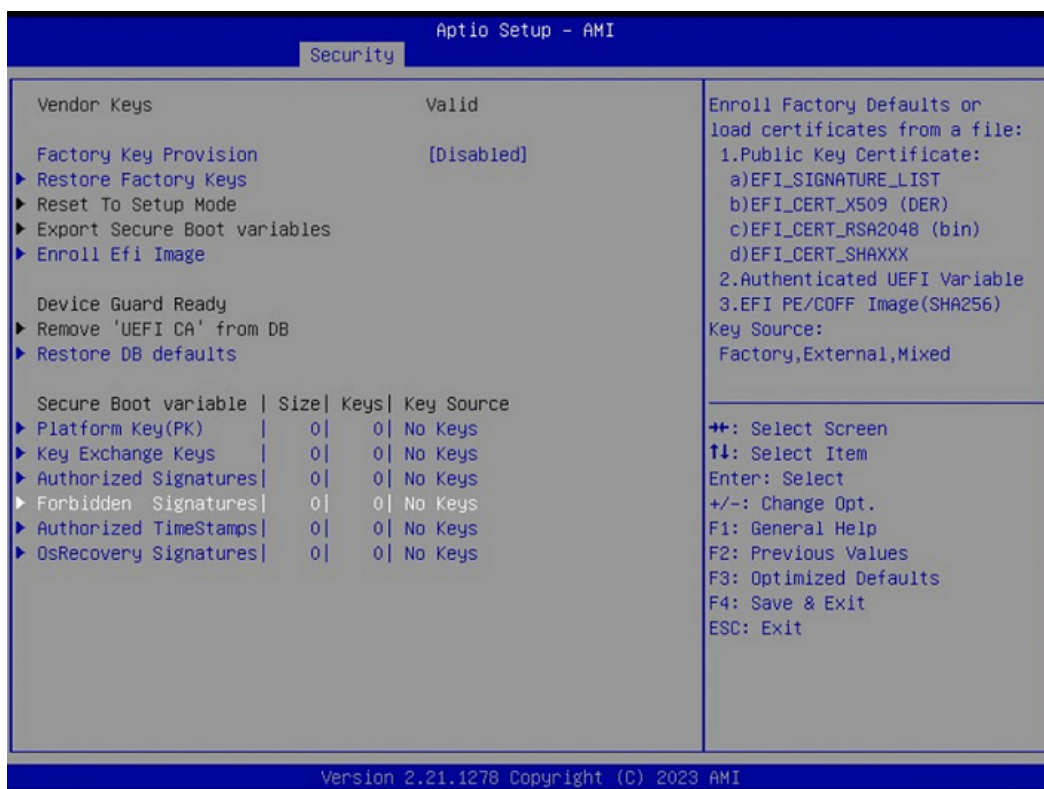

Figure 4.34 Secure Boot

4.5 Boot

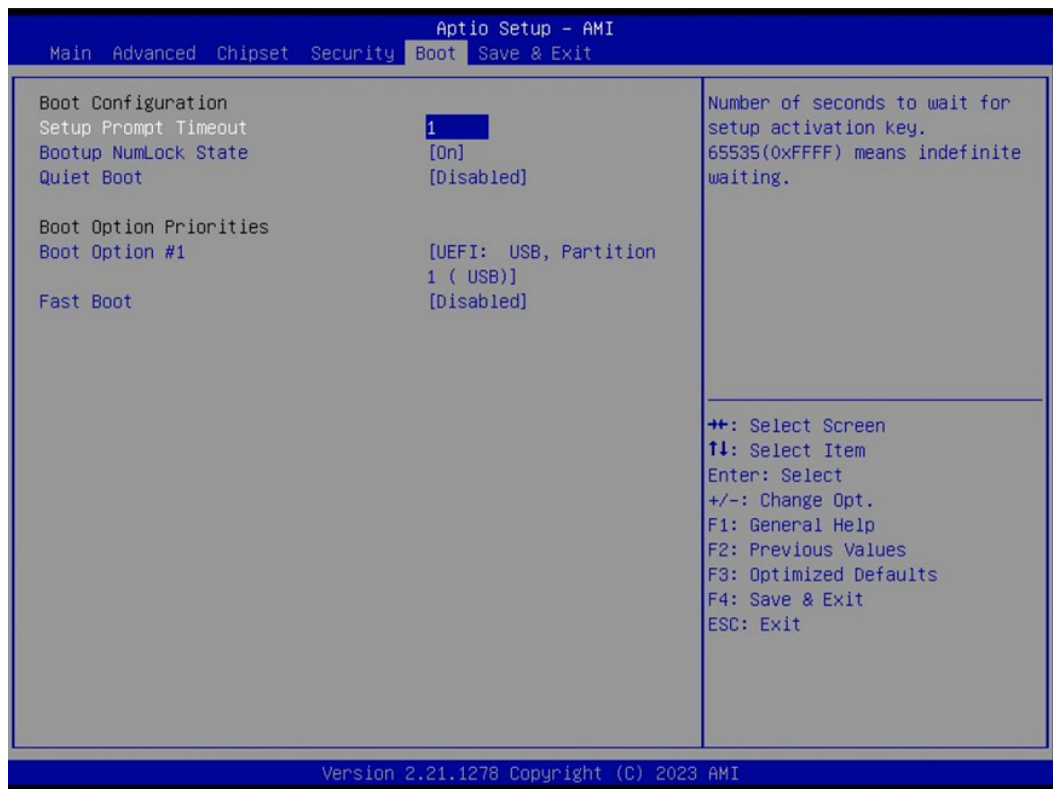

Figure 4.35 Boot

- **Boot Configuration**
 - **Setup Prompt Timeout**

Number of seconds to wait for setup activation key. 65535(0xFFFF) means indefinite waiting.
 - **Bootup NumLock State**

Select the keyboard NumLock state.
 - **Quiet Boot**

Enable/Disable Quiet Boot option.
- **Boot Priorities**
 - **Boot Option #1**

Select the system boot order.
 - **Fast Boot**

4.6 Save & Exit

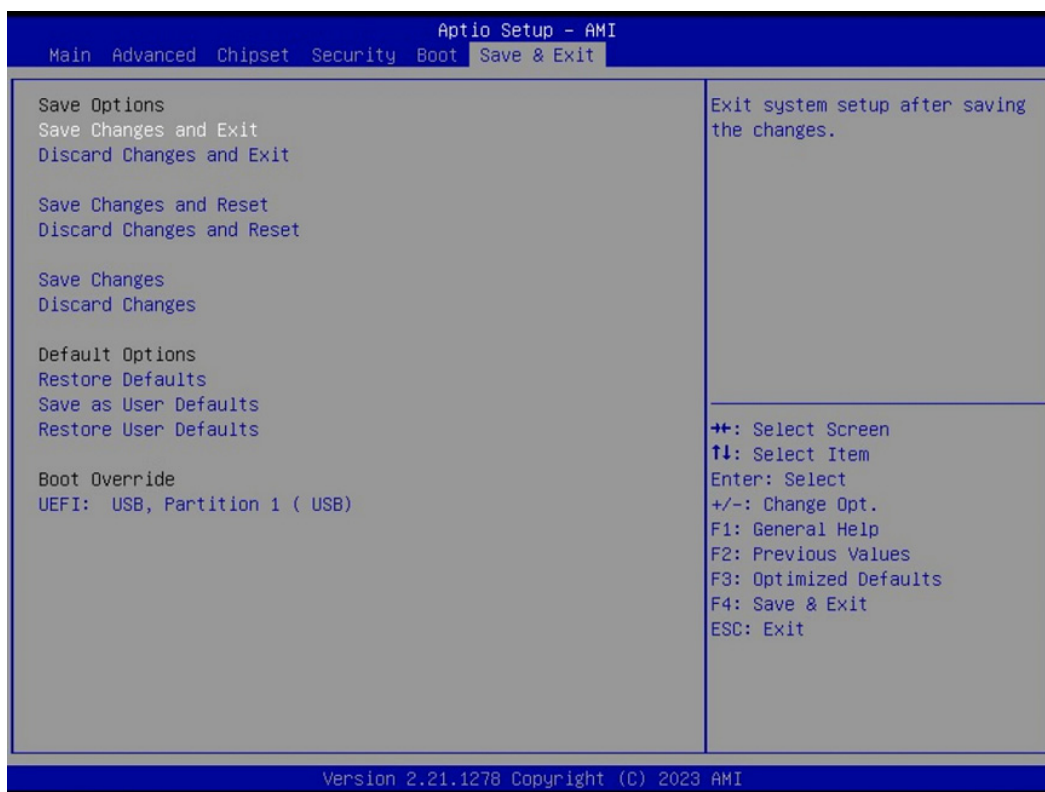

Figure 4.36 Save & Exit

- **Save Options**
- **Save Changes and Exit**
Exit system setup after saving the changes.
- **Discard Changes and Exit**
Exit system setup without saving any changes.
- **Save Changes and Reset**
Reset the system after saving the changes.
- **Discard Changes and Reset**
Reset system setup without saving any changes.
- **Save Changes**
Save any changes done so far to any of the setup options.
- **Discard Changes**
Discard changes done so far to any of the setup options.
- **Restore Defaults**
Restore/ load default values for all the setup options.
- **Saves as User Defaults**
Save the changes done so far as User defaults.
- **Restore User Defaults**
Restore the user defaults t all the setup options.
- **UEFI: USB Hard Drive, Partition 1**

Appendix **A**

System Settings/Pin
Assignments

A.1 Power Connector (DCIN1)

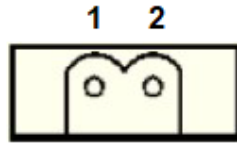

Table A.1: Power Connector Pin Assignments

Pin	Signal	Description
1	Power IN V+	10 - 36 V _{DC}
2	Power IN V- (GND)	

A.2 Clear CMOS Function (CMOS1)

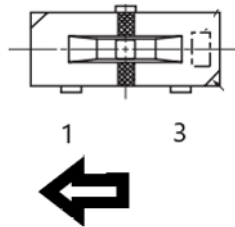

Table A.2: Clear CMOS Function (CMOS1)

CMOS1	CMOS Clear Function
Description	This jumper is used to select CMOS Clear Enable/Disable
(2-3)	Enable (Clear CMOS)
(1-2)	Disable (Default)

A.3 USB Connector

A.3.1 USB 2.0 Connector (USB2A1)

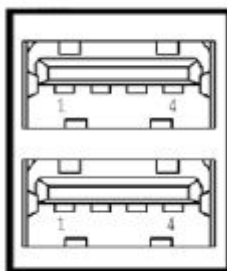

Table A.3: USB Pin Assignments

Pin	Signal Name	Description
1	VBUS	Power
2	D-	USB2.0 differential pair
3	D+	
4	GND	Ground for power return

A.3.2 USB 3.2 Connector (USB3A1/USB3A2/USB3A3)

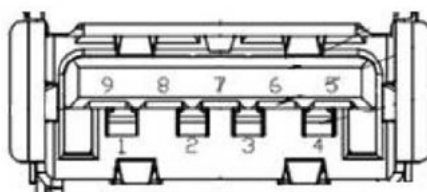

Table A.4: USB Pin Assignments

Pin	Signal Name	Description
1	VBUS	Power
2	D-	USB2.0 differential pair
3	D+	
4	GND	Ground for power return
5	StdA_SSRX-	SuperSpeed receiver differential pair
6	StdA_SSRX+	
7	GND_DRIAN	Ground for signal return
8	StdA_SSTX-	SuperSpeed transmitter differential pair
9	StdA_SSTX+	

A.4 HDMI Connector (HDMI1)

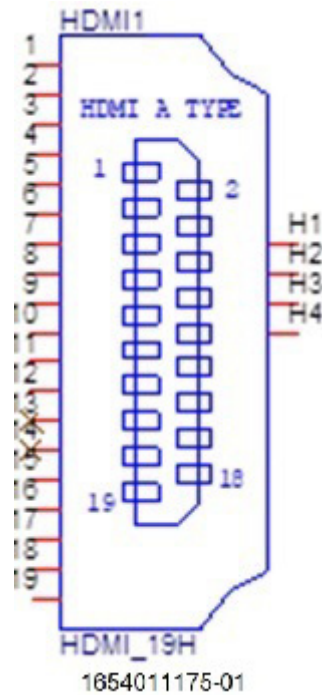

Table A.5: HDMI Port Adapter Cable Pin Assignments

Pin	Signal Name
1	TMDS1_a_P0
2	GND
3	TMDS1_a_N0
4	TMDS1_a_P1
5	GND
6	TMDS1_a_N1
7	TMDS1_a_P2
8	GND
9	TMDS1_a_N2
10	TMDS1_CLK_a_P
11	GND
12	TMDS1_CLK_a_N
13	NC
14	NC
15	TMDS1_DDCCLK
16	TMDS1_DDCDAT
17	GND
18	+V5
19	TMDS1_HPD

A.5 COM Port RS232/422/485 Settings

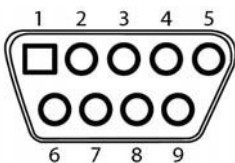

Table A.6: COM Port RS232/422/485 Settings

Pin	RS232	RS422	RS485
1	DCD	TX-	D-
2	RX	TX+	D+
3	TX	RX+	
4	DTR	RX-	
5	GND	GND	GND
6	DSR		
7	RTS		
8	CTS		
9	RI		

A.6 LAN1/2/3/4 RJ45 Connector

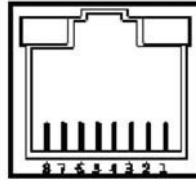

Table A.7: LAN1/2/3/4 RJ45 Connector

RJ45 Pin	Signal	Description
1	MDI0+	<ul style="list-style-type: none"> In BASE-T: Media Dependent Interface{0} 1000BASE-T: In MDI configuration MDI{0}+/- corresponds to BI_DA+/- and in MDI-X configuration MDI{0}=-/- corresponds to BI_DB+/-
2	MDI0-	<ul style="list-style-type: none"> 10BASE-T and 100BASE-T: In MD configuration MD{0}+/- is used for the transmit pair and in MDIX configuration MDI{0}+/- is used for the receive pair.
3	MDI1+	<ul style="list-style-type: none"> In BASE-T: Media Dependent Interface{1}: 1000BASE-T: In MDI configuration, MDI{1}+/- corresponds to BI_DB+/- and in MDI-X configuration MDI{1}+/- corresponds to BI_DA+/-
6	MDI1-	<ul style="list-style-type: none"> 10BASE-T and 100BASE-TX: In MDI configuration MDI{1} is used for the receive pair and in MDI-X configuration MDI{1}+/- is used for the transmit pair.
4	MDI2+	<ul style="list-style-type: none"> In BASE-T: Media-dependent interface[3:2]:
5	MDI2-	<ul style="list-style-type: none"> 1000BASE-T: In MDI and in MDI-X configuration, MDI{2}+/- corresponds to BI_DC+/- and MDI{3}+/- corresponds to BI_DD+/-.
7	MDI3+	<ul style="list-style-type: none"> 100BASE-TX: Unused.
8	MDI3-	<ul style="list-style-type: none"> 10BASE-T: Unused.

Table A.8: LED (I226)

Left LED		Right LED	
100/10 Link.	1000 Linke	2500 Link.	Active
Off	Orange	Green	Green

Table A.9: LED (I219)

Left LED			Right LED		
10Mbps (off)	100Mbps (off)	1000Mbps (Orange)	2500Mbps (Green)	Link (Green)	Active (Green Flash)

A.7 GPIO Port (GPIO1)

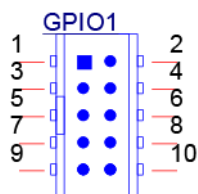

1653004099
BH_5x2V_S2.00mm
BH5x2P-S2.00

The GPIO port can connect to DB9 connector for extension module.

Table A.10: GPIO Port (GPIO1)

Pin	Signal Name
1	+V5
2	GPIO0
3	GPIO1
4	GPIO2
5	GPIO3
6	GPIO4
7	GPIO5
8	GPIO6
9	GPIO7

A.8 DP Connector (DP1)

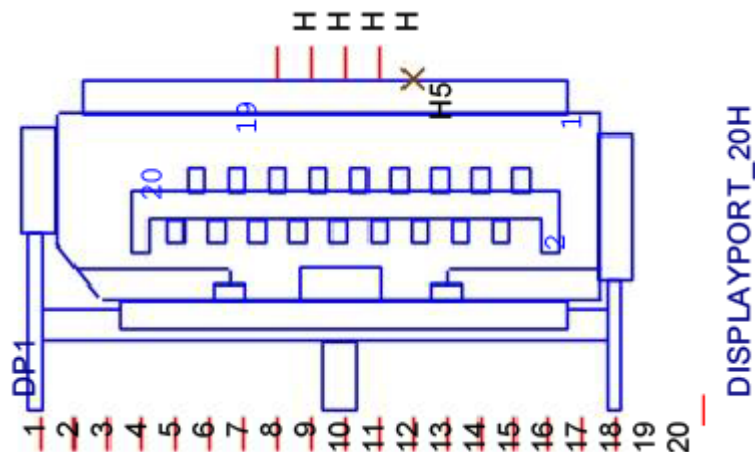

Table A.11: Display Port Adapter Cable Pin Assignments

Pin	Signal Name
1	DP0_z_D0+
2	GND
3	DP0_z_D0-
4	DP0_z_D1+
5	GND
6	DP0_z_D1-
7	DP0_z_D2+
8	GND
9	DP0_z_D2-
10	DP0_z_D3+
11	GND
12	DP0_z_D3-
13	DP0_AUX_EN#
14	DP0_CONFIG
15	DP0_AUX_P
16	GND
17	DP0_AUX_N
18	DP0_z_HPD
19	GND
20	+V3.3

A.9 Type-C Connector (TYPEC1)

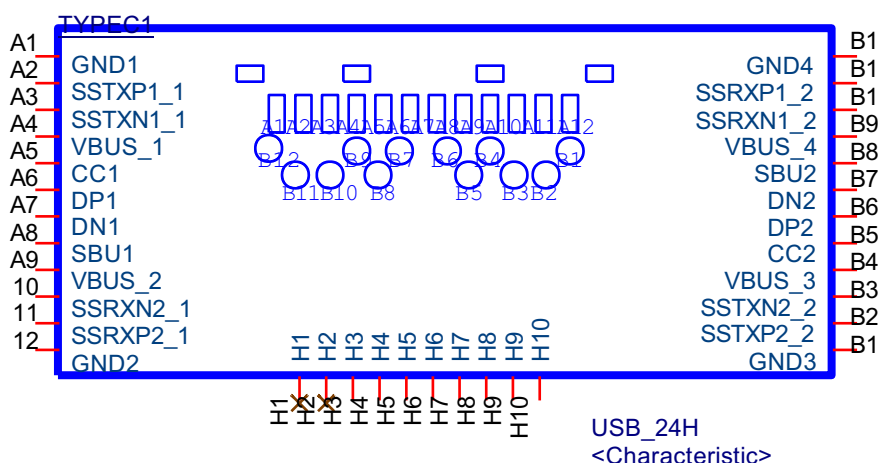

Table A.12: mPCIe Connector Pin Assignments

Pin	Signal Name	Pin	Signal Name
A1	GND	B1	GND
A2	USBC_TXP0_CON	B2	USBC_RXP0_CON
A3	USBC_TXN0_CON	B3	USBC_RXN0_CON
A4	+V5BUS_CON	B4	+V5BUS_CON
A5	CCG5_CC1_CON	B5	USBC_SBU2_CON
A6	USB2_PCH_TYPEC1_a_D_P	B6	USB2_PCH_TYPEC_a_D_N
A7	USB2_PCH_TYPEC1_a_D_N	B7	USB2_PCH_TYPEC_a_D_P
A8	USBC_SBU1_CON	B8	CCG5_CC2_CON
A9	+V5BUS_CON	B9	+V5BUS_CON
A10	USBC_RXN1_CON	B10	USBC_TXN1_CON
A11	USBC_RXP1_CON	B11	USBC_TXP1_CON
A12	GND	B12	GND

A.10 AT/ATX Setting (PSON1)

PSON1 can be used for AT/ATX setting. The default setting is ATX mode. See the following table for jumper configuration.

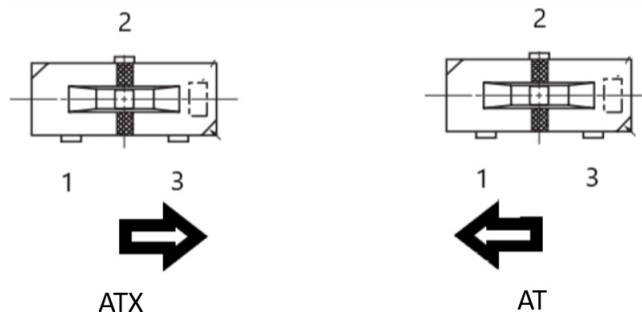
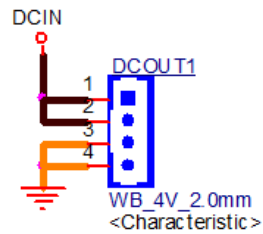

Table A.13: AT/ATX Setting (PSON1)

Closed Pins	Result
1-2	AT mode
2-3	*ATX mode

A.11 DC in Setting (DCOUT1)

DCOUT1 can be used for iDoor modules. The power input follows iDoor module specifications.



A.12 Slide Switch Setting (SW1)

SW1 is designed for 5G modules. The slide switch on the right-hand side is currently in the "on" position. The default configuration has pin 1 through pin 4 set to "on." Please adhere to the 5G module requirements when adjusting the slide switch settings.

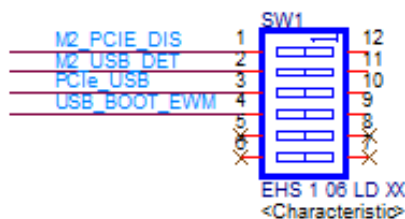

SW1
 SIERA(M.2_Pin20/22)
 Pin1 H = USB L/Floating = PCIe
 Pin2 H = USB L/Floating = PCIe
 Neoway(M.2_Pin38)
 Pin3 H = USB L/Floating = PCIe
 AIW-315(M.2_Pin38)
 Pin3 Floating = 5Gmode
 EWM(M.2_Pin68)
 Pin4 H = USB L/Floating = PCIe

A.13 Remote Power Setting (FP1)

FP1 can be used for an iDoor module to connect to power.

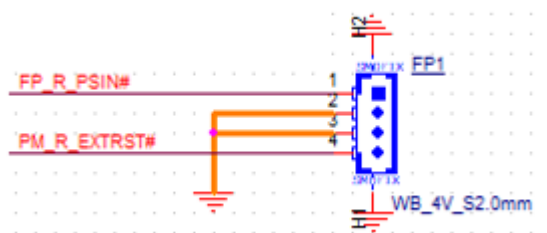

A.14 RAID0/RAID1 Setting

To enable RAID0/RAID1 support, follow the steps outlined below to activate VMD:

1. Enter the BIOS setup menu.
2. Navigate to Chipset -> System Agent (SA) Configuration -> VMD setup menu.
3. Set "Enable VMD controller" to "Enable."
4. Also, under Chipset -> System Agent (SA) Configuration -> VMD setup menu, ensure that "Map this Root Port under VMD" is set to "Enable."
5. Enter the BIOS setup menu again.
6. Navigate to Advanced -> Intel Rapid Storage Technology.
7. Choose "Create RAID volume."
8. Save the changes and exit the BIOS.
9. Install the Intel Rapid Storage Technology (RST) driver from the official Intel website.

www.advantech.com

Please verify specifications before quoting. This guide is intended for reference purposes only.

All product specifications are subject to change without notice.

No part of this publication may be reproduced in any form or by any means, such as electronically, by photocopying, recording, or otherwise, without prior written permission from the publisher.

All brand and product names are trademarks or registered trademarks of their respective companies.

© Advantech Co., Ltd. 2026